

**SHIELD**<sup>TM</sup>

*Trusted Worldwide*

# EXPANSION JOINTS

(BRAIDED LOOPS)

Flexible & Reliable Joints for Seismic Applications





# INTRODUCTION

SHIELD is a company created to cater to the infrastructure, fire protection and building services industries with a comprehensive range of products designed to be competitive and of assured quality.

We stay ahead of today's evolving market requirements by committing to a program of continued research and development.

We are able to maintain our high standards by ensuring that our worldwide manufacturing networks are the most advanced in the industry in Europe, Asia and America in terms of quality and delivery lead time. Our fully experienced and professional staff is there to provide engineering expertise and after sales service exactly when you need it.

Combine this with highly responsive and customer focused network of distribution centres around the world, you will find that customer satisfaction is what we excel at.

We are justifiably proud of our global client base. With offices and facilities in the UK and Middle East, we are able to comprehend the specific needs of your particular region.

# TABLE OF CONTENTS

**1** ——— **SHIELD Expansion Joints**

1	<i>Description</i>
1	<i>Design &amp; Structure</i>
1	<i>Specifications</i>
1	<i>Operating Conditions</i>

**3 - 6** ——— **U-flex**

3	<i>Braided Loop Joints</i>
3	<i>Welded End</i>
4	<i>Flanged End</i>
5	<i>Grooved End</i>
6	<i>Threaded End</i>

**8 - 11** ——— **V-flex**

8	<i>Braided Loop Joints</i>
8	<i>Welded End</i>
9	<i>Flanged End</i>
10	<i>Grooved End</i>
11	<i>Threaded End</i>



# SHIELD SEISMIC PROTECTION

# SHIELD Expansion Joints



## Description:

SHIELD Expansion Joints (U-Flex and V-Flex) provide extremely reliable and flexible movement in the piping system deployed in firefighting, HVAC, water and fluid carrying domestic and industrial system. These are FM Approved (SD-UFLEX Expansion Loop, SD-VFLEX Expansion Loop) Expansion Joints. The joints act as shock absorbers during seismic shocks and safeguard the piping system from potential break down and critical losses. SHIELD U-Flex and V-Flex assemblies prevent piping's structural deformations such as cracks and break downs of rigid connections by the required flexibility. They offer easy, safe and reliable solution to secure the piping system.

## A Perfect Seismic Protection Solution

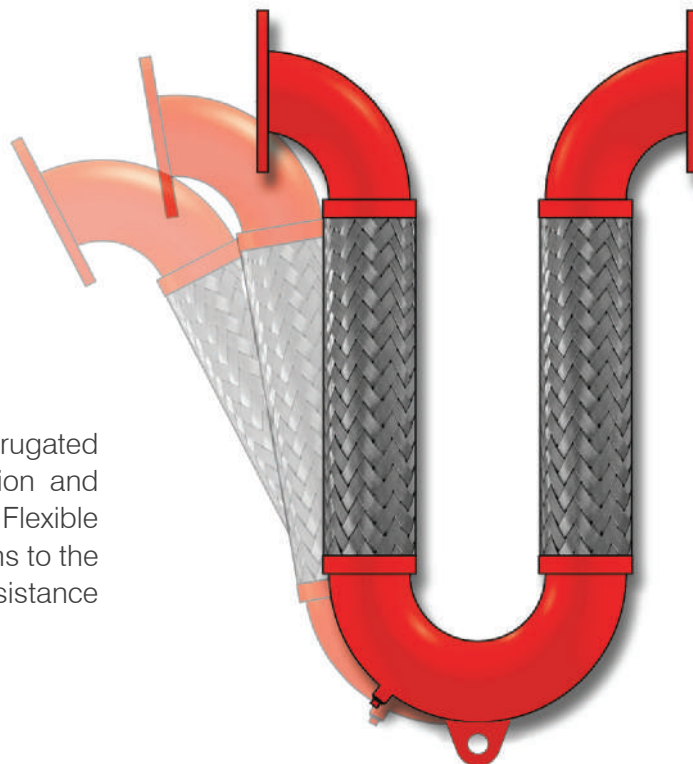

## Design & Structure:

SHIELD U-Flex and V-Flex assemblies consist of parallel corrugated metal hose with braiding through Carbon Steel connection and direction parts such as turns and elbows at various angles. Flexible metal hose provides high movement capacity in all directions to the assemblies and the braiding increases the pressure resistance accordingly.

## Specifications:

- Bellow Material                      Stainless Steel AISI 304 / AISI 316L / AISI 321
- Braiding Material                   Stainless Steel AISI 304
- Connection Types                  Flanged End, Welded End, Grooved End and Threaded End
- Flange Material                     Carbon Steel St. 37.2, the material can be customized on request
- Elbow and Turn Material          Carbon Steel St. 37.2, the material can be customized on request.

## Operating Conditions:

### Operating Temperature

-80 °C to +600 °C

### Operating Pressure

250psi (FM Approved)

### Nominal Diameters

DN15 (1/2") - DN250 (10")



# Building with SHIELD Expansion Joints

## Before Seismic Effects

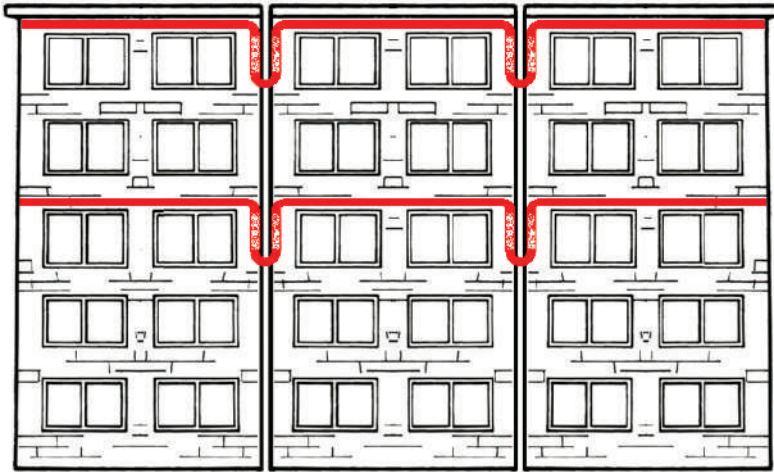

Factory  
Mutual  
System

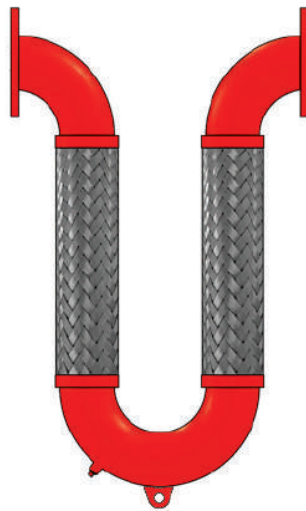

## After Seismic Effects

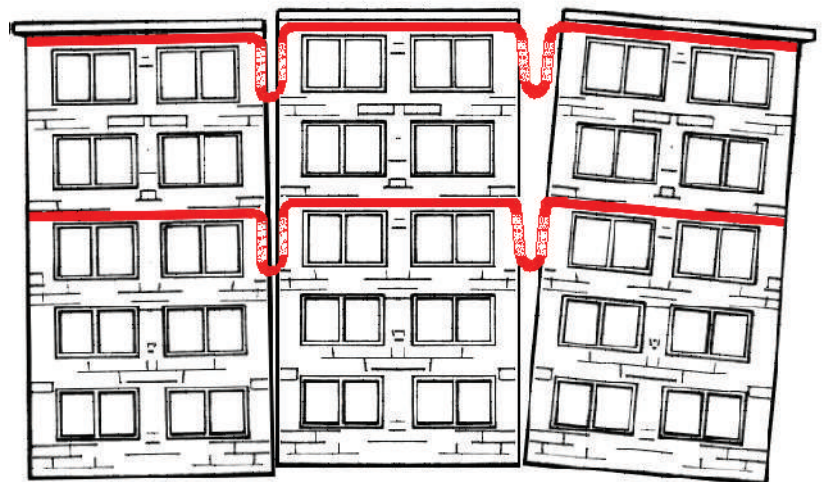

## Braided Loop Joints:

SHIELD U-Flex, "SD-UFLEX Expansion Loop" Available Types (Standard Versions)

Model	Movement Amount - All Plates	Design Pressure	Description
	mm		
SD-UFW	± 37.5 , ± 100.0 , ± 200.0	250	U-type, 3D Braided Loop-Joint, Welded End
SD-UFF	± 37.5 , ± 100.0 , ± 200.0	250	U-type, 3D Braided Loop-Joint, Flanged End
SD-UFG	± 37.5 , ± 100.0 , ± 200.0	250	U-type, 3D Braided Loop-Joint, Grooved End
SD-UFT	± 37.5 , ± 100.0 , ± 200.0	250	U-type, 3D Braided Loop-Joint, Threaded End

## Welded End:

SD-UFW

Model	Nominal Diameter	Nominal Pipe Size	Ødi	Movement in all directions		L	H
				mm	Inch		
SD-UFW-25	DN 25	1	33.7	±37.5	±1.5	152	380
				±100.0	±4.0	254	510
				±200.0	±8.0	322	795
SD-UFW-32	DN 32	1¼	42.4	±37.5	±1.5	190	410
				±100.0	±4.0	273	535
				±200.0	±8.0	350	870
SD-UFW-40	DN 40	1½	48.3	±37.5	±1.5	228	435
				±100.0	±4.0	292	585
				±200.0	±8.0	378	960
SD-UFW-50	DN 50	2	60.3	±37.5	±1.5	304	485
				±100.0	±4.0	356	635
				±200.0	±8.0	424	1050
SD-UFW-65	DN 65	2½	76.1	±37.5	±1.5	380	535
				±100.0	±4.0	380	715
				±200.0	±8.0	480	1110
SD-UFW-80	DN 80	3	88.9	±37.5	±1.5	456	585
				±100.0	±4.0	456	762
				±200.0	±8.0	526	1165
SD-UFW-100	DN 100	4	114.3	±37.5	±1.5	608	715
				±100.0	±4.0	608	890
				±200.0	±8.0	658	1380
SD-UFW-125	DN 125	5	141.3	±37.5	±1.5	760	815
				±100.0	±4.0	760	1020
				±200.0	±8.0	760	1455
SD-UFW-150	DN 150	6	168.3	±37.5	±1.5	916	940
				±100.0	±4.0	920	1170
				±200.0	±8.0	916	1565
SD-UFW-200	DN 200	8	219.1	±37.5	±1.5	1220	1220
				±100.0	±4.0	1220	1475
				±200.0	±8.0	1220	1780
SD-UFW-250	DN 250	10	273.0	±37.5	±1.5	1524	1400
				±100.0	±4.0	1524	1702
				±200.0	±8.0	1524	1975

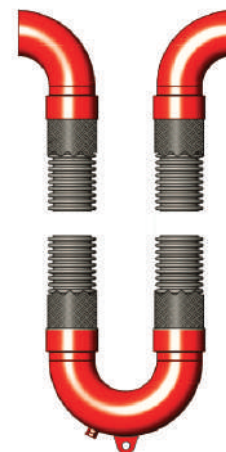
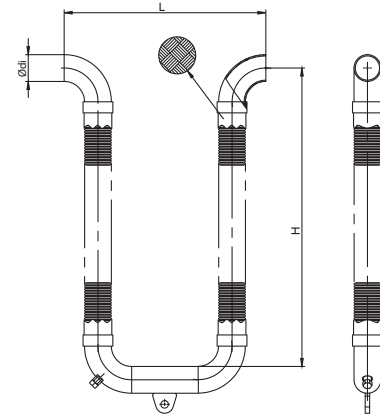
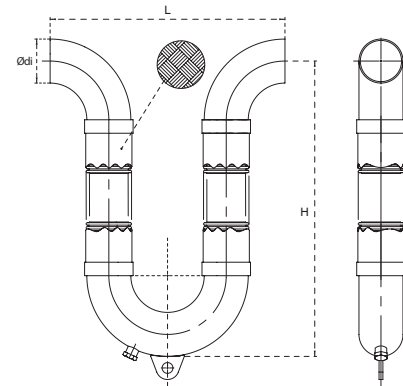

## Flanged End:

SD-UFF

Model	Nominal Diameter	Nominal Pipe Size	Flange (DIN EN 1092/1) PN 16					Movement in all directions		L	H
			ØD	Øk	b	Ødxn	Ød4	mm	Inch		
	mm	Inch	mm	mm	mm	mm	mm		mm	mm	
SD-UFF-25	DN 25	1	115	85	16	14 x 4	68	± 37.5	± 1.5	222	380
								± 100.0	± 4.0	324	510
								± 200.0	± 8.0	395	888
SD-UFF-32	DN 32	1¼	140	100	16	18 x 4	78	± 37.5	± 1.5	260	410
								± 100.0	± 4.0	343	535
								± 200.0	± 8.0	415	987
SD-UFF-40	DN 40	1½	150	110	16	18 x 4	88	± 37.5	± 1.5	300	435
								± 100.0	± 4.0	362	585
								± 200.0	± 8.0	455	1099
SD-UFF-50	DN 50	2	165	125	18	18 x 4	102	± 37.5	± 1.5	375	485
								± 100.0	± 4.0	426	635
								± 200.0	± 8.0	500	1233
SD-UFF-65	DN 65	2½	185	145	18	18 x 4	122	± 37.5	± 1.5	450	535
								± 100.0	± 4.0	450	715
								± 200.0	± 8.0	555	1339
SD-UFF-80	DN 80	3	200	160	20	18 x 8	138	± 37.5	± 1.5	536	585
								± 100.0	± 4.0	536	765
								± 200.0	± 8.0	605	1438
SD-UFF-100	DN 100	4	220	180	20	18 x 8	158	± 37.5	± 1.5	680	715
								± 100.0	± 4.0	680	890
								± 200.0	± 8.0	745	1742
SD-UFF-125	DN 125	5	250	210	22	18 x 8	188	± 37.5	± 1.5	832	815
								± 100.0	± 4.0	832	1020
								± 200.0	± 8.0	850	1905
SD-UFF-150	DN 150	6	285	240	22	23 x 8	212	± 37.5	± 1.5	988	940
								± 100.0	± 4.0	988	1170
								± 200.0	± 8.0	1010	2108
SD-UFF-200	DN 200	8	340	295	24	23 x 12	268	± 37.5	± 1.5	1292	1220
								± 100.0	± 4.0	1292	1475
								± 200.0	± 8.0	1315	2500
SD-UFF-250	DN 250	10	405	355	26	27 x 12	320	± 37.5	± 1.5	1600	1400
								± 100.0	± 4.0	1600	1702
								± 200.0	± 8.0	1630	2874

Other flange types are made according to different standards (ANSI/ASME, BS, & UNI), are also available upon request.

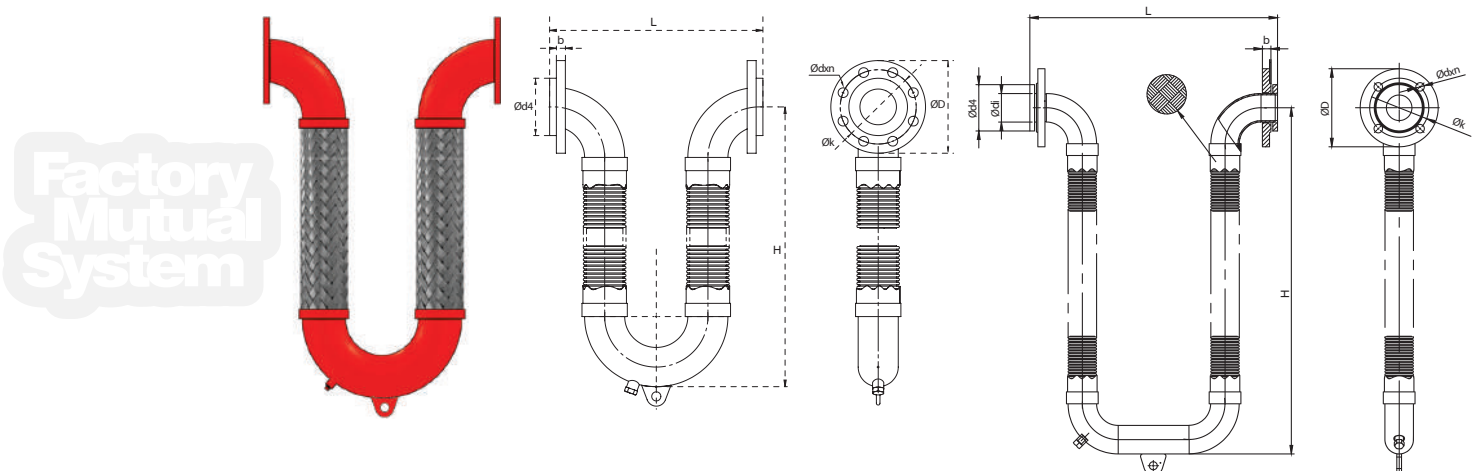

# U-Flex

## Grooved End:

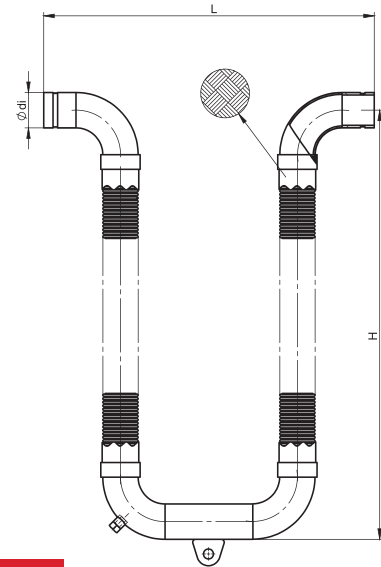
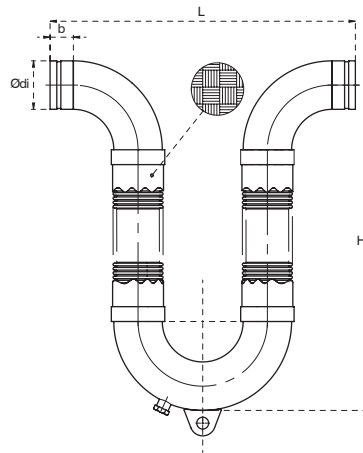

FM

APPROVED

## SD-UFG

Model	Nominal Diameter	Nominal Pipe Size	Ødi	b	Movement in all directions		L	H
					mm	Inch		
SD-UFG-25	DN 25	1	33.7	55	±37.5	±1.5	262	380
					±100.0	±4.0	364	510
					±200.0	±8.0	435	888
SD-UFG-32	DN 32	1¼	42.4	55	±37.5	±1.5	300	410
					±100.0	±4.0	383	535
					±200.0	±8.0	460	987
SD-UFG-40	DN 40	1½	48.3	55	±37.5	±1.5	338	435
					±100.0	±4.0	402	585
					±200.0	±8.0	490	1099
SD-UFG-50	DN 50	2	60.3	55	±37.5	±1.5	414	485
					±100.0	±4.0	466	635
					±200.0	±8.0	535	1233
SD-UFG-65	DN 65	2½	76.1	55	±37.5	±1.5	491	535
					±100.0	±4.0	490	715
					±200.0	±8.0	590	1339
SD-UFG-80	DN 80	3	88.9	55	±37.5	±1.5	568	585
					±100.0	±4.0	566	762
					±200.0	±8.0	640	1438
SD-UFG-100	DN 100	4	114.3	55	±37.5	±1.5	720	715
					±100.0	±4.0	718	890
					±200.0	±8.0	770	1742
SD-UFG-125	DN 125	5	139.7	60	±37.5	±1.5	882	815
					±100.0	±4.0	880	1020
					±200.0	±8.0	880	1905
SD-UFG-150	DN 150	6	168.3	60	±37.5	±1.5	1034	940
					±100.0	±4.0	1040	1170
					±200.0	±8.0	1040	2108
SD-UFG-200	DN 200	8	219.1	65	±37.5	±1.5	1350	1220
					±100.0	±4.0	1350	1475
					±200.0	±8.0	1355	2500
SD-UFG-250	DN 250	10	273.0	65	±37.5	±1.5	1654	1400
					±100.0	±4.0	1654	1702
					±200.0	±8.0	1660	2874

## Threaded End:

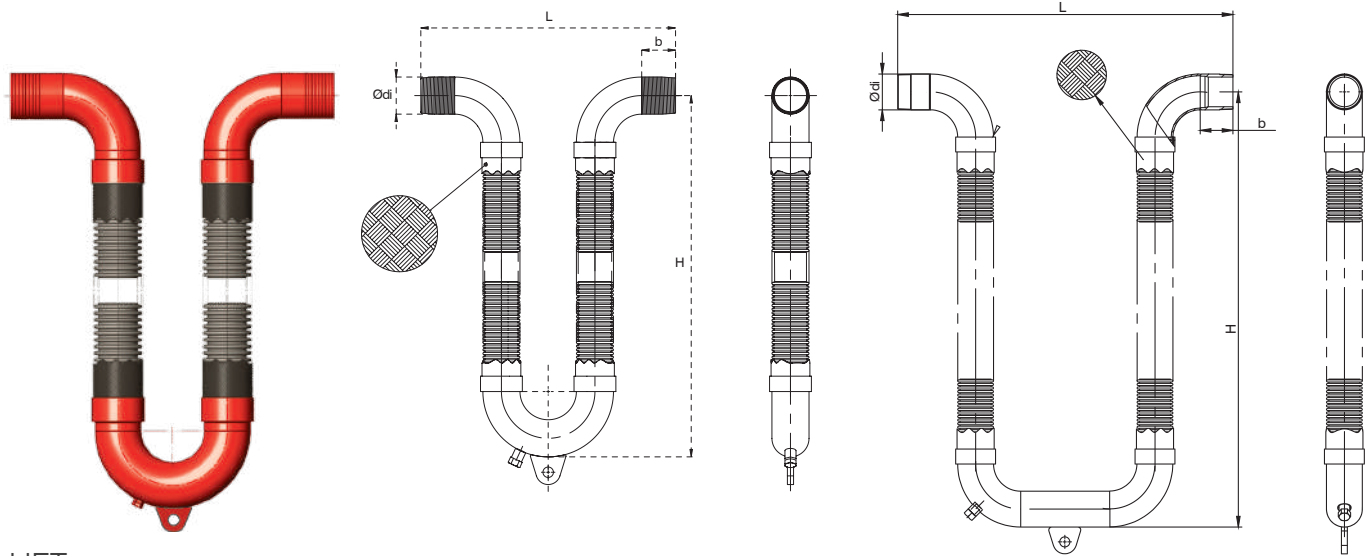

## SD-UFT

Model	Nominal Diameter	Nominal Pipe Size	Ødi	b	Movement in all directions		L	H
					mm	Inch		
SD-UFT-25	DN 25	1	33.7	55	± 37.5	± 1.5	262	380
					± 100.0	± 4.0	364	510
					± 200.0	± 8.0	435	888
SD-UFT-32	DN 32	1¼	42.4	55	± 37.5	± 1.5	300	410
					± 100.0	± 4.0	383	535
					± 200.0	± 8.0	460	987
SD-UFT-40	DN 40	1½	48.3	55	± 37.5	± 1.5	338	435
					± 100.0	± 4.0	402	585
					± 200.0	± 8.0	490	1099
SD-UFT-50	DN 50	2	60.3	55	± 37.5	± 1.5	414	485
					± 100.0	± 4.0	466	635
					± 200.0	± 8.0	535	1233
SD-UFT-65	DN 65	2½	76.1	55	± 37.5	± 1.5	491	535
					± 100.0	± 4.0	490	715
					± 200.0	± 8.0	590	1339
SD-UFT-80	DN 80	3	88.9	55	± 37.5	± 1.5	568	585
					± 100.0	± 4.0	566	762
					± 200.0	± 8.0	640	1438
SD-UFT-100	DN 100	4	114.3	55	± 37.5	± 1.5	720	715
					± 100.0	± 4.0	718	890
					± 200.0	± 8.0	770	1742
SD-UFT-125	DN 125	5	141.3	60	± 37.5	± 1.5	882	815
					± 100.0	± 4.0	880	1020
					± 200.0	± 8.0	880	1905
SD-UFT-150	DN 150	6	168.3	60	± 37.5	± 1.5	1034	940
					± 100.0	± 4.0	1040	1170
					± 200.0	± 8.0	1040	2108
SD-UFT-200	DN200	8	219.1		± 37.5	± 1.5	000	000
					± 100.0	± 4.0	000	000
					± 200.0	± 8.0	1355	2500
SD-UFT-250	DN250	10	273		± 37.5	± 1.5	000	000
					± 100.0	± 4.0	000	000
					± 200.0	± 8.0	1660	2874



# A stronger bond for building integrity in worst events



**Factory  
Mutual  
System**

Seismic flexible braided expansion joint is a distinctive product which can easily absorb the lateral offset and angular movements.

## Braided Loop Joints:

SHIELD V-Flex, "SD-VFLEX Expansion Loop" Available Types (Standard Versions)

Model	Movement Amount - All Plates	Design Pressure	Description
	mm		
SD-VFW	± 37.5 , ± 100.0 , ± 200.0	250	V-type, 3D Braided Loop-Joint, Welded End
SD-VFF	± 37.5 , ± 100.0 , ± 200.0	250	V-type, 3D Braided Loop-Joint, Flanged End
SD-VFG	± 37.5 , ± 100.0 , ± 200.0	250	V-type, 3D Braided Loop-Joint, Grooved End
SD-VFT	± 37.5 , ± 100.0 , ± 200.0	250	V-type, 3D Braided Loop-Joint, Threaded End

## Welded End:

SD-VFW

Model	Nominal Diameter	Nominal Pipe Size	Ødi	Movement in all directions		L	H
				mm	Inch		
SD-VFW-25	DN 25	1	33.7	± 37.5	± 1.5	450	330
				± 100.0	± 4.0	637	492
				± 200.0	± 8.0	1040	839
SD-VFW-32	DN 32	1¼	42.4	± 37.5	± 1.5	467	330
				± 100.0	± 4.0	680	515
				± 200.0	± 8.0	1160	931
SD-VFW-40	DN 40	1½	48.3	± 37.5	± 1.5	484	330
				± 100.0	± 4.0	737	549
				± 200.0	± 8.0	1295	1030
SD-VFW-50	DN 50	2	60.3	± 37.5	± 1.5	568	370
				± 100.0	± 4.0	815	584
				± 200.0	± 8.0	1470	1150
SD-VFW-65	DN 65	2½	76.1	± 37.5	± 1.5	679	436
				± 100.0	± 4.0	950	670
				± 200.0	± 8.0	1602	1233
SD-VFW-80	DN 80	3	88.9	± 37.5	± 1.5	768	480
				± 100.0	± 4.0	1065	739
				± 200.0	± 8.0	1732	1315
SD-VFW-100	DN 100	4	114.3	± 37.5	± 1.5	933	560
				± 100.0	± 4.0	1248	834
				± 200.0	± 8.0	2115	1582
SD-VFW-125	DN 125	5	141.3	± 37.5	± 1.5	1110	650
				± 100.0	± 4.0	1480	872
				± 200.0	± 8.0	2335	1711
SD-VFW-150	DN 150	6	168.3	± 37.5	± 1.5	1297	750
				± 100.0	± 4.0	1687	1088
				± 200.0	± 8.0	2595	1872
SD-VFW-200	DN 200	8	219.1	± 37.5	± 1.5	1617	900
				± 100.0	± 4.0	2027	1255
				± 200.0	± 8.0	3205	2251
SD-VFW-250	DN 250	10	273.0	± 37.5	± 1.5	1970	1080
				± 100.0	± 4.0	2440	1488
				± 200.0	± 8.0	3702	2554

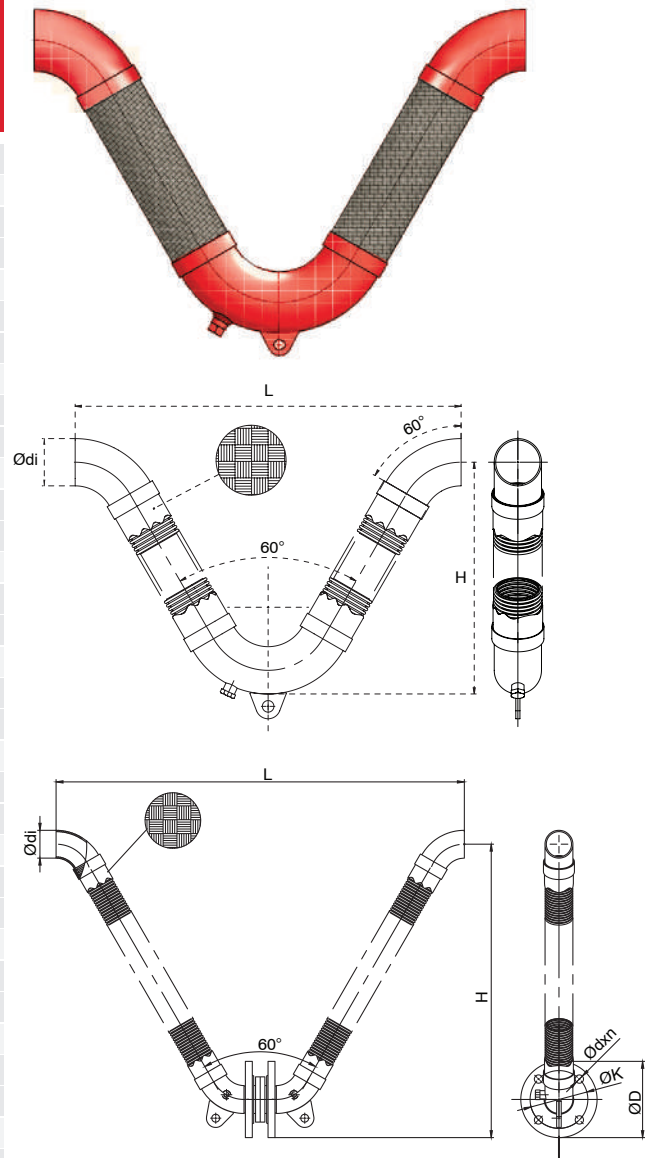

# V-Flex

## Flanged End:

### SD-VFF

Model	Nominal Diameter	Nominal Pipe Size	Flange (DIN EN 1092/1) PN 16					Movement in all directions		L	H
			ØD mm	Øk mm	b mm	Ødxn mm	Ød4 mm	mm	Inch		
SD-VFF-25	DN 25	1	115	85	16	14 x 4	68	± 37.5	± 1.5	520	330
								± 100.0	± 4.0	707	492
								± 200.0	± 8.0	1115	839
SD-VFF-32	DN 32	1¼	140	100	16	18 x 4	78	± 37.5	± 1.5	537	330
								± 100.0	± 4.0	750	515
								± 200.0	± 8.0	1226	931
SD-VFF-40	DN 40	1½	150	110	16	18 x 4	88	± 37.5	± 1.5	554	330
								± 100.0	± 4.0	807	549
								± 200.0	± 8.0	1372	1030
SD-VFF-50	DN 50	2	165	125	18	18 x 4	102	± 37.5	± 1.5	638	370
								± 100.0	± 4.0	885	584
								± 200.0	± 8.0	1547	1150
SD-VFF-65	DN 65	2½	185	145	18	18 x 4	122	± 37.5	± 1.5	749	436
								± 100.0	± 4.0	1020	670
								± 200.0	± 8.0	1677	1233
SD-VFF-80	DN 80	3	200	160	20	18 x 8	138	± 37.5	± 1.5	838	480
								± 100.0	± 4.0	1135	739
								± 200.0	± 8.0	1812	1315
SD-VFF-100	DN 100	4	220	180	20	18 x 8	158	± 37.5	± 1.5	1005	560
								± 100.0	± 4.0	1320	834
								± 200.0	± 8.0	2200	1582
SD-VFF-125	DN 125	5	250	210	22	18 x 8	188	± 37.5	± 1.5	1182	650
								± 100.0	± 4.0	1552	972
								± 200.0	± 8.0	2425	1711
SD-VFF-150	DN 150	6	285	240	22	23 x 8	212	± 37.5	± 1.5	1369	750
								± 100.0	± 4.0	1759	1088
								± 200.0	± 8.0	2690	1872
SD-VFF-200	DN 200	8	340	295	24	23 x 12	268	± 37.5	± 1.5	1689	900
								± 100.0	± 4.0	2102	1255
								± 200.0	± 8.0	3300	2261
SD-VFF-250	DN 250	10	405	355	26	27 x 12	320	± 37.5	± 1.5	2045	1080
								± 100.0	± 4.0	2515	1487
								± 200.0	± 8.0	3810	2564

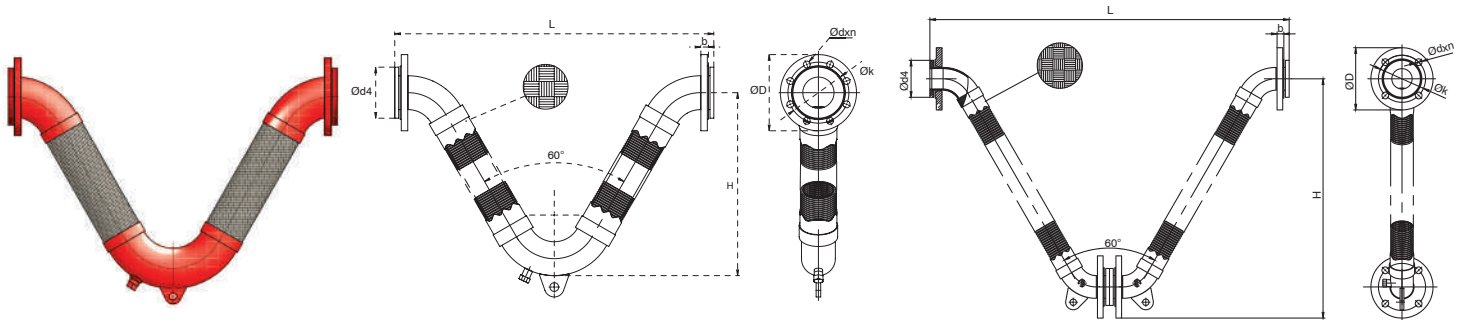

Other flange types are made according to different standards (ANSI/ASME, BS, & UNI), are also available upon request.  
 \* SHIELD reserves the right to change the contents without notice.

## Grooved End:

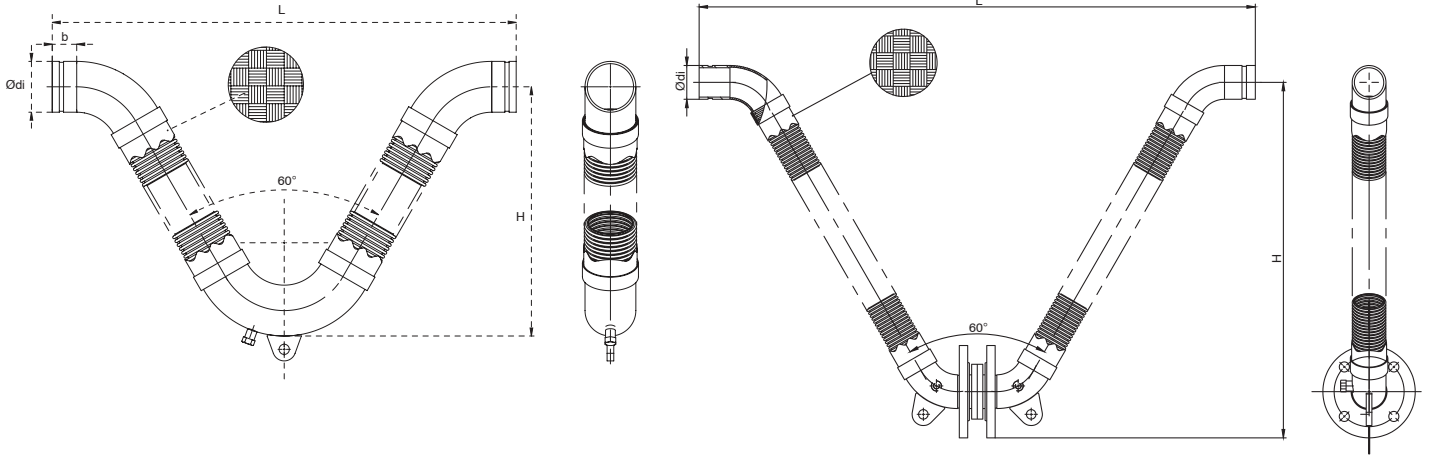

## SD-VFG

Model	Nominal Diameter	Nominal Pipe Size	Ødi	b	Movement in all directions		L	H
					mm	Inch		
SD-VFG-25	DN 25	1	33.7	55	±37.5	±1.5	560	330
					±100.0	±4.0	747	492
					±200.0	±8.0	1150	839
SD-VFG-32	DN 32	1¼	42.4	55	±37.5	±1.5	577	330
					±100.0	±4.0	790	515
					±200.0	±8.0	1270	931
SD-VFG-40	DN 40	1½	48.3	55	±37.5	±1.5	594	330
					±100.0	±4.0	847	549
					±200.0	±8.0	1405	1030
SD-VFG-50	DN 50	2	60.3	55	±37.5	±1.5	678	370
					±100.0	±4.0	925	582
					±200.0	±8.0	1580	1150
SD-VFG-65	DN 65	2½	76.1	55	±37.5	±1.5	789	436
					±100.0	±4.0	1060	670
					±200.0	±8.0	1712	1233
SD-VFG-80	DN 80	3	88.9	55	±37.5	±1.5	878	480
					±100.0	±4.0	1175	739
					±200.0	±8.0	1842	1315
SD-VFG-100	DN 100	4	114.3	55	±37.5	±1.5	1043	560
					±100.0	±4.0	1358	833
					±200.0	±8.0	2225	1582
SD-VFG-125	DN 125	5	141.3	60	±37.5	±1.5	1230	650
					±100.0	±4.0	1600	970
					±200.0	±8.0	2455	1711
SD-VFG-150	DN 150	6	168.3	60	±37.5	±1.5	1417	750
					±100.0	±4.0	1807	1088
					±200.0	±8.0	2715	1872
SD-VFG-200	DN 200	8	219.1	65	±37.5	±1.5	1747	900
					±100.0	±4.0	2157	1255
					±200.0	±8.0	3335	2261
SD-VFG-250	DN 250	10	273.0	65	±37.5	±1.5	2100	1080
					±100.0	±4.0	2570	1487
					±200.0	±8.0	3832	2564

# V-Flex

## Threaded End:

### SD-VFT

Model	Nominal Diameter	Nominal Pipe Size	Ødi	b	Movement in all directions		L	H
					mm	Inch		
SD-VFT-25	DN 25	1	33.7	55	±37.5	±1.5	560	330
					±100.0	±4.0	747	492
					±200.0	±8.0	1150	839
SD-VFT-32	DN 32	1¼	42.4	55	±37.5	±1.5	577	330
					±100.0	±4.0	790	515
					±200.0	±8.0	1270	931
SD-VFT-40	DN 40	1½	48.3	55	±37.5	±1.5	594	330
					±100.0	±4.0	847	549
					±200.0	±8.0	1405	1030
SD-VFT-50	DN 50	2	60.3	55	±37.5	±1.5	678	370
					±100.0	±4.0	925	582
					±200.0	±8.0	1580	1150
SD-VFT-65	DN 65	2½	76.1	55	±37.5	±1.5	789	436
					±100.0	±4.0	1060	670
					±200.0	±8.0	1712	1233
SD-VFT-80	DN 80	3	88.9	55	±37.5	±1.5	878	480
					±100.0	±4.0	1175	739
					±200.0	±8.0	1842	1315
SD-VFT-100	DN 100	4	114.3	55	±37.5	±1.5	1043	560
					±100.0	±4.0	1358	833
					±200.0	±8.0	2225	1582
SD-VFT-125	DN 125	5	141.3	60	±37.5	±1.5	1230	650
					±100.0	±4.0	1600	970
					±200.0	±8.0	2455	1711
SD-VFT-150	DN 150	6	168.3	60	±37.5	±1.5	1417	750
					±100.0	±4.0	1807	1088
					±200.0	±8.0	2715	1872

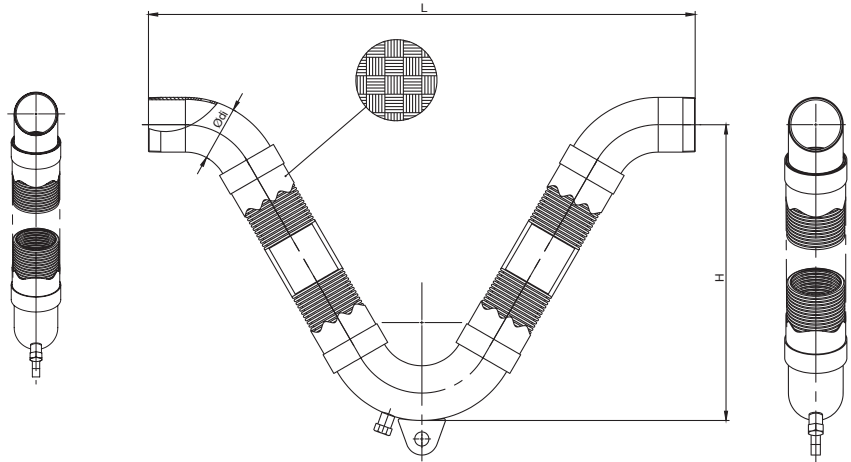
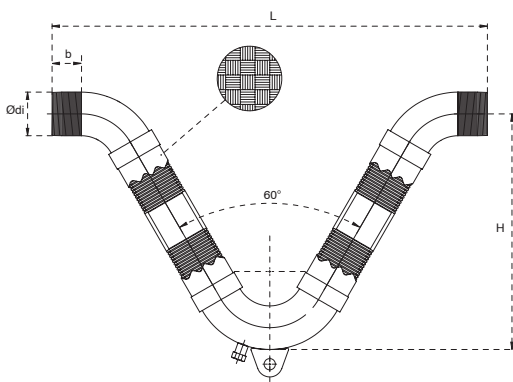

# U-Flex Installation Instructions



# U-Flex

## Motion of Braided Loop Joints

Braided Loop Joints designed to move in any direction, all-in-one joint for a variety of applications. It can also be designed with lines hose for high velocity, double-braid for high pressure and all stainless steel construction for media compatibility. Loop Joints has no limit to handle seismic applications.

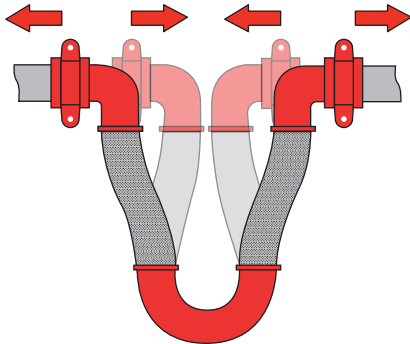

Axial Compression and Extension

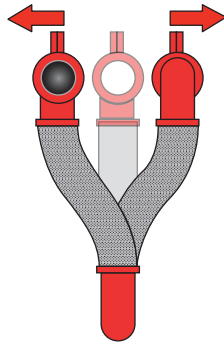

Parallel Offset "Z" axis

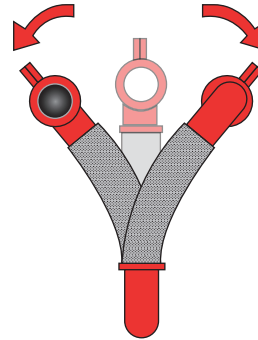

Parallel Offset with "X" axis rotation

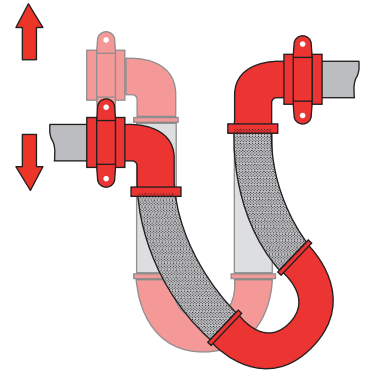

Non-Parallel Offset "Y" axis

## Connection Types of Loop Joints



### Horizontal Connection ( Hanging Down)

Loop Joints should hang straight down and free to flex. Guides are required to direct movement axially.

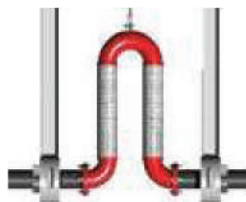

### Horizontal Connection ( Straight Up)

Support the loop to prevent from leaning. Pipe hanger rod should be loose enough to allow the 180° return to move up or down 1/4", as the loop flexes. Guides are required to direct movement of pipe axially.



### Horizontal Connection

Support the loop to prevent from drooping or torquing pipe. Allow 180° return to move horizontally back and forth 1/4", as the loop flexes. Guides are required to direct movement of pipe axially. It is recommended for steam.

# U-Flex

## Types of U-Flex Connection



### Vertical Connection

Support the U-Flex to allow 180° return to move horizontally back and forth 1/4" as the loop flexes. Guides are required to direct movement of pipe axially.



### Nested Connection

For tight pipe runs, any size or number of loops can be designed to nest inside of one another. To order, specify sequence of pipe diameters and corresponding distances between pipe centerlines.



### Inside Corner Connection

Single U-Flex simultaneously absorbs the thermal expansion of two pipe runs. Saving space from inside corner joint connection eliminates the need for an anchor at the corner. Support the U-Flex to prevent from drooping or torquing pipe and allow for sufficient movement. Guides are required to direct movement of pipe axially.



### Over-Under Connection

The U-Flex expansion loop can be manufactured in a variety of configurations.

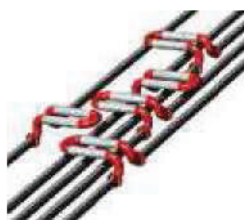

### Over-Over Connection

The U-Flex expansion loop can be manufactured in a variety of configurations.

# U-Flex

## Installation Instructions

1. Shield U-Flex fire protection hose can connect to adjacent pipeline with flanges, welding ends or grooved connection using rigid or flexible couplings.
2. U-Flex can be installed in any position or orientation with maximum efficiency.
3. If the U-Flex is smaller than 2" no support is required for the 180° return bend.
4. If the U-Flex is larger than 2" and hanged down vertically, no supprt is required. For other orientations, support has to provide in any of the below mentioned ways:
  - For the +/- 4" (100mm) movement of the U-Flex a hanger rod which is 12" (300mm) or greater will allow the loop to swing properly in order to maintain the security.
  - In case that the U-Flex is forced to be installed with hanging rod that is shorter than recommended distance above, it is suggested to use a spring hanger. Spring type of hangers may provide the required flexibility to the assembly during seismic.
5. Distance of support from expansion joint should be minimum 4 time pipe dia.
6. U-Flex are supplied with spreader bars to prevent misalignment during installation. This bar should be removed after installation.
7. For movement of +/-4" (100mm) must have 4" clearance all around the U-Flex.
8. If U-Flex can't span the building's seismic separation, it is suggested to install it with the closest elbow not more than 24" (600mm) from seismic separation.
9. While installing U-Flex in vertically uprighth position (180° bend above the pipeline) the entrapped air should be removed.

## Minimum required force for U-Flex Activation

Size	250 PSI Pressure					
	4" Movement			8" Movement		
	Axial Force (kN)	Vertical Force (kN)	Transverse Force (kN)	Axial Force (kN)	Vertical Force (kN)	Transverse Force (kN)
DN100	1.20	0.47	0.82	1.45	0.58	1
DN125	1.35	0.55	0.90	2.50	1.90	2.30
DN150	4	1.2	3	6	1.75	4.40
DN200	9	4	4.20	13	5.90	6.50



For further information on any aspect of the SHIELD range of Expansion Joints please contact your nearest office.

**UNITED KINGDOM**

Unit 3, Endeavour Drive,  
Basildon-Essex, SS14 3WF,  
United Kingdom.  
Email: [info@shieldglobal.com](mailto:info@shieldglobal.com)  
Tel: +44 1708 377731  
Fax: +44 1708 347637

**MIDDLE EAST & AFRICA**

Jebel Ali Free Zone, Dubai, UAE  
Email: [shieldme@shieldglobal.com](mailto:shieldme@shieldglobal.com)  
Tel: +971 4 881 2070  
Fax: +971 4 881 2198