

# BUTT WELD

FITTINGS & FLANGES

High Quality Products for Best Results





## INTRODUCTION

SHIELD is a company created to cater to the infrastructure, fire protection and building services industries with a comprehensive range of products designed to be competitive and of assured quality.

We stay ahead of today's evolving market requirements by committing to a program of continued research and development.

We are able to maintain our high standards by ensuring that our worldwide manufacturing networks are the most advanced in the industry in Europe, Asia and America in terms of quality and delivery lead time. Our fully experienced and professional staff is there to provide engineering expertise and after sales service exactly when you need it.

Combine this with highly responsive and customer focused network of distribution centres around the world, you will find that customer satisfaction is what we excel at.

We are justifiably proud of our global client base. With offices and facilities in the UK and Middle East, we are able to comprehend the specific needs of your particular region.

# TABLE OF CONTENTS

<b>1</b>	<b>Butt-weld Fittings</b>
<b>2</b>	<b>Fittings Wall Thickness</b>
<b>4 - 6</b>	<b>Elbows</b>
4	<i>Long Radius Elbow 90°</i>
5	<i>Long Radius Elbow 45°</i>
6	<i>Short Radius Elbow 90°</i>
<b>7</b>	<b>Tees</b>
7	<i>Equal Tee</i>
7	<i>Cross Tee</i>
<b>8 - 15</b>	<b>Reducers</b>
8	<i>Reducer Tee</i>
8	<i>Reducer Cross</i>
11	<i>Concetric Reducer</i>
11	<i>Eccentric Reducer</i>
14	<i>Reducing Elbow 90°</i>
<b>16 - 17</b>	<b>Bends</b>
16	<i>Long Radius Bend 180°</i>
17	<i>Short Radius Bend 180°</i>
<b>18</b>	<b>Cap</b>
18	<i>End Cap</i>
<b>20 - 33</b>	<b>Flanges</b>
20	<i>Flange</i>
21	<i>Blind Flange - Class 150</i>
22	<i>Blind Flange - Class 300</i>
23	<i>Slip-on Flange - Class 150</i>
24	<i>Slip-on Flange - Class 300</i>
26	<i>Welded Flange - Class 150</i>
27	<i>Welded Flange - Class 300</i>
28	<i>Blind Flange - PN10, 16 &amp; 25</i>
30	<i>Slip-on Flange - PN10, 16 &amp; 25</i>
32	<i>Weld Neck Flange - PN10, 16 &amp; 25</i>



# SHIELD BUTT-WELD FITTINGS

# Butt-weld Fittings

## Description:

### The Fittings

Butt-weld fittings are used in a piping system for changing direction, branching and to mechanically joined to the system. A piping system using Butt-weld fittings has many inherent advantages over other forms. Butt-weld fittings are used widely in high pressure and high temperature application.

### Material

Material specification is totally in compliance with ASTM A 234. This standard covers wrought carbon steel fittings of seamless and welded construction which are manufactured to the dimensional specifications of ASME B16.9. These fittings are primarily for use in pressure piping and in pressure vessel fabrication for service at moderate and elevated temperatures. The starting material for fittings consist of killed (de-oxidized) steel, forgings, bars, plates; seamless or fusion-welded tubular products with filler metal added and conform to the Mechanical & Chemical requirements of ASTM A 234.

### Chemical Requirements (in %)

C	Mn	P	S	Si	Cr	Mb	Ni	Cu	V
Max		Max	Max	Min	Max	Max	Max	Max	Max
0.30	0.29-1.06	0.050	0.058	0.10	0.40	0.15	0.40	0.40	0.08

### Mechanical Requirements

Tensile Strength	Yield Strength	Elongation
Min	Min	Min
60,000 psi	35,000 psi	22%



### Dimensions

Butt-weld fittings are manufactured in accordance with this specification conforms to the dimensions and tolerances given in the latest revision of ASME B16.9 & B16.28.

### Manufacturing Process

Forging or shaping operations are performed by hammering, pressing, piercing, extruding, upsetting, rolling, bending, fusion welding or by combination of two or more of these operations.

### Heat Treatment

Hot-formed WPB fittings, upon which the final forming operation is completed at a temperature above 1150 °F (620 °C) and below 1800 °F (980 °C), need not be heat-treated (provided they are cooled in air). Cold-Formed WPB fittings, upon which the final forming operation is completed at a temperature below 1150 °F (620 °C), and normalized, or stress relieved at 1100 °F (595 °C) to 1275 °F (690 °C).



# Fittings Wall Thickness

## Schedule of Wall Thickness:

Schedule 40

Nominal Pipe Size	Wall Thickness		
	SCH 40 mm	SCH STD mm	XS mm
Inch			
1/4	2.24	2.24	3.02
1/2	2.77	2.77	3.73
3/4	2.87	2.87	3.91
1	3.38	3.38	4.55
1 1/4	3.56	3.56	4.85
1 1/2	3.68	3.68	5.08
2	3.91	3.91	5.54
2 1/2	5.16	5.16	7.01
3	5.49	5.49	7.62
3 1/2	5.74	5.74	8.08
4	6.02	6.02	8.56
5	6.55	6.55	9.52
6	7.11	7.11	10.97
8	8.18	8.18	12.70
10	9.27	9.27	12.70
12	10.31	9.52	12.70
14	11.13	9.52	12.70
16	12.70	9.52	12.70
18	14.27	9.52	12.70
20	15.09	9.52	12.70
24	17.48	9.52	12.70
26	-	9.52	12.70
28	-	9.52	12.70
30	-	9.52	12.70
32	-	9.52	12.70
34	-	9.52	12.70
36	-	9.52	12.70
38	-	9.52	12.70
40	-	9.52	12.70
42	-	9.52	12.70
44	-	9.52	12.70
46	-	9.52	12.70
48	-	9.52	12.70



*SHIELD Butt-weld fittings are intended for applications requiring the unwavering quality of a welded tubing framework. They are produced particularly for installation, utilizing automatic and orbital welding hardware. These fittings offer the simplest, speediest and most dependable approach to create welded systems. Shield Butt-weld fittings are capable of passing hydrostatic test compatible with the pressure rating of the specified matching pipe.*





# Carbon Steel

## Butt-weld fittings



Butt-weld fittings are used in a piping system for changing direction, branching and to mechanically joined to the system. Butt-weld fittings are used widely in high pressure and high temperature application.

# Elbows

## Long Radius Elbow 90°:

SD-BLRE 90

Nominal Pipe Size	Outside Diameter D mm	Centre to End
		A mm
Inch		
1/2	21.3	38
3/4	26.7	38
1	33.4	38
1 1/4	42.2	48
1 1/2	48.3	57
2	60.3	76
2 1/2	73.0	95
3	88.9	114
3 1/2	101.6	133
4	114.3	152
5	141.3	190
6	168.3	229
8	219.1	305
10	273.0	381
12	323.8	457
14	355.6	533
16	406.4	610
18	457.0	686
20	508.0	762
22	559.0	838
24	610.0	914
26	660.0	991
28	711.0	1067
30	762.0	1143
32	813.0	1219
34	864.0	1295
36	914.0	1372
38	965.0	1448
40	1016.0	1524
42	1067.0	1600
44	1118.0	1676
46	1168.0	1753
48	1219.0	1829

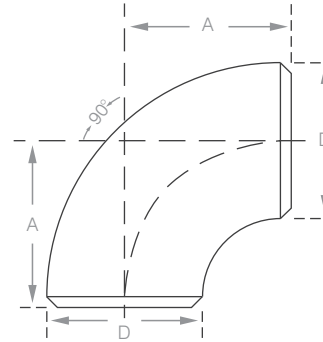

### Functions:

The function of the elbow is to change direction or flow in a piping system. Elbows are split as follows, the distance over which they change direction; the centre line of one end to the opposite face, this is known as the "centre to face" distance and is equivalent to the radius through which the elbow is bent.

### Material:

ASTM A234 Grade WPB

### Dimension:

ASME B16.9



*A pipe fitting is defined as a part used in a piping system to change direction or function and to mechanically joined to the system.*

# Elbows

## Long Radius Elbow 45°:

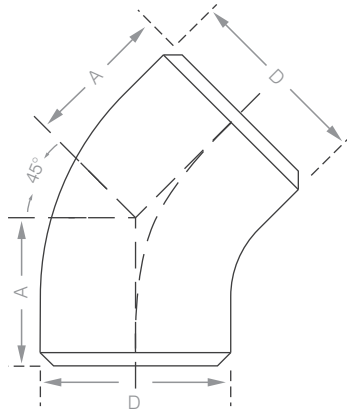

### Functions:

The function of a 45° elbow is the same as a 90° elbow, but the measurement of dimensions is different. The radius of a 45° elbow is the same as the radius of the 90° long radius elbow where 'R' equals 1½ D. However, the centre to face dimension is measured from each face to the point of intersection of the centre lines perpendicular to each other. This is due to the smaller degree of bend.

### Material:

ASTM A234 Grade WPB

### Dimension:

ASME B16.9



### SD-BLRE 45

Nominal Pipe Size	Outside Diameter D mm	Centre to End A mm
Inch	mm	mm
½	21.3	16
¾	26.7	19
1	33.4	22
1¼	42.2	25
1½	48.3	29
2	60.3	35
2½	73.0	44
3	88.9	51
3½	101.6	57
4	114.3	64
5	141.3	79
6	168.3	95
8	219.1	127
10	273.0	159
12	323.8	190
14	355.6	222
16	406.4	254
18	457.0	286
20	508.0	318
22	559.0	343
24	610.0	381
26	660.0	406
28	711.0	438
30	762.0	470
32	813.0	502
34	864.0	533
36	914.0	565
38	965.0	600
40	1016.0	632
42	1067.0	660
44	1118.0	695
46	1168.0	727
48	1219.0	759

# Elbows

## Short Radius Elbow 90°:

SD-BSRE 90

Nominal Pipe Size	Outside Diameter D mm	Centre to End
		A mm
Inch		
1	33.4	25
1¼	42.2	32
1½	48.3	38
2	60.3	51
2½	73.0	64
3	88.9	76
3½	101.6	89
4	114.3	102
5	141.3	127
6	168.3	152
8	219.1	203
10	273.0	254
12	323.8	305
14	355.6	356
16	406.4	406
18	457.0	457
20	508.0	508
22	559.0	559
24	610.0	610

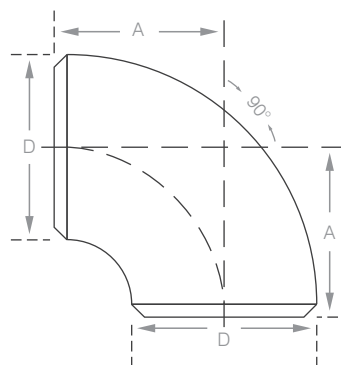

### Functions:

A Short radius elbow gives a sharpen turn to the piping system as compared to long radius elbow. Short radius elbow is less in space consumption than long radius elbow, cost effective and high efficiency.

### Material:

ASTM A234 Grade WPB

### Dimension:

ASME B16.9 & B16.28



# Tees

## Equal Tee: SD-BET

**Functions:**

The function of a tee is to permit flow at 90° to the main direction of flow. The main flow passes through the 'run' while the 90° outlet is known as the 'branch'. The equal tee is manufactured with all three outlets being the same size.

**Material:**

ASTM A234 Grade WPB

**Dimension:**

ASME B16.9

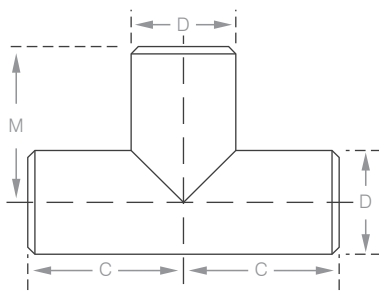

Equal Tee



## SD-BET & SD-BCT

Nominal Pipe Size Inch	Outside Diameter D mm	Centre to End	
		C mm	M mm
1/2	21.3	25	25
3/4	26.7	29	29
1	33.4	38	38
1 1/4	42.2	48	48
1 1/2	48.3	57	57
2	60.3	64	64
2 1/2	73.0	76	76
3	88.9	86	86
3 1/2	101.6	95	95
4	114.3	105	105
5	141.3	124	124
6	168.3	143	143
8	219.1	178	178
10	273.0	216	216
12	323.8	254	254
14	355.6	279	279
16	406.4	305	305
18	457.0	343	343
20	508.0	381	381
22	559.0	419	419
24	610.0	432	432
26	660.0	495	495
28	711.0	521	521
30	762.0	559	559
32	813.0	597	597
34	864.0	635	635
36	914.0	673	673
38	965.0	711	711
40	1016.0	749	749
42	1067.0	762	711
44	1118.0	813	762
46	1168.0	851	800
48	1219.0	889	838

## Cross Tee: SD-BCT

**Functions:**

The function of a cross is similar to that of equal tee with the exception of providing two 90° outlets opposite each other. Equal crosses have all four outlets of equal size.

**Material:**

ASTM A234 Grade WPB

**Dimension:**

ASME B16.9

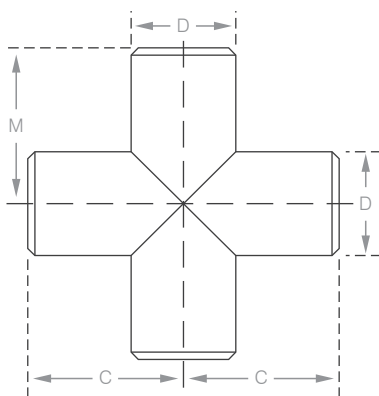

Cross Tee



# Reducers

## SD-BRT & SD-BRC

Nominal Pipe Size Inch	Outside Diameter		Centre to End	
	D mm	D1 mm	C mm	M mm
1/2 x 1/4	21.3	13.7	25	25
1/2 x 3/8	21.3	17.3	25	25
3/4 x 3/8	26.7	17.3	29	29
3/4 x 1/2	26.7	21.3	29	29
1 x 1/2	33.4	21.3	38	38
1 x 3/4	33.4	26.7	38	38
1 1/4 x 1/2	42.2	21.3	48	48
1 1/4 x 3/4	42.2	26.7	48	48
1 1/4 x 1	42.2	33.4	48	48
1 1/2 x 1/2	48.3	21.3	57	57
1 1/2 x 3/4	48.3	26.7	57	57
1 1/2 x 1	48.3	33.4	57	57
1 1/2 x 1 1/4	48.3	42.2	57	57
2 x 3/4	60.3	26.7	64	44
2 x 1	60.3	33.4	64	51
2 x 1 1/4	60.3	42.2	64	57
2 x 1 1/2	60.3	48.3	64	60
2 1/2 x 1	73.0	33.4	76	57
2 1/2 x 1 1/4	73.0	42.2	76	64
2 1/2 x 1 1/2	73.0	48.3	76	67
2 1/2 x 2	73.0	60.3	76	70
3 x 1 1/4	88.9	42.2	86	70
3 x 1 1/2	88.9	48.3	86	73
3 x 2	88.9	60.3	86	76
3 x 2 1/2	88.9	73.0	86	83
3 1/2 x 1 1/2	101.6	48.3	95	79
3 1/2 x 2	101.6	60.3	95	83
3 1/2 x 2 1/2	101.6	73.0	95	89
3 1/2 x 3	101.6	88.9	95	92
4 x 1 1/2	114.3	48.3	105	86
4 x 2	114.3	60.3	105	89
4 x 2 1/2	114.3	73.0	105	95
4 x 3	114.3	88.9	105	98
4 x 3 1/2	114.3	101.6	105	102
5 x 2	141.3	60.3	124	105
5 x 2 1/2	141.3	73.0	124	108
5 x 3	141.3	88.9	124	111

(Cont.)

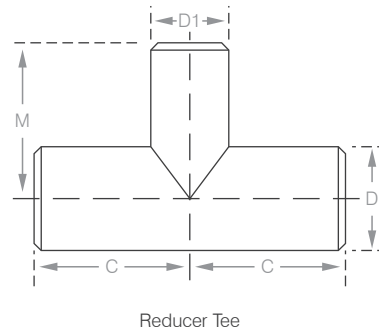

## Reducer Tee: SD-BRT Reducer Cross: SD-BRC

### Functions:

The reducing tee and cross are manufactured with the branch outlet smaller than the run to obtain the desired flow and pressure through the system.

### Material:

ASTM A234 Grade WPB

### Dimension:

ASME B16.9

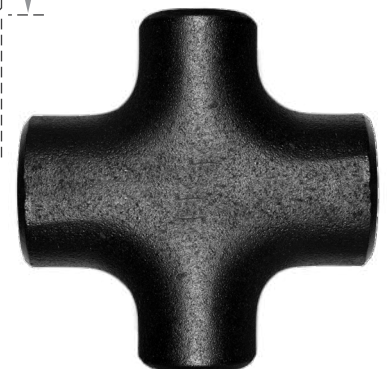
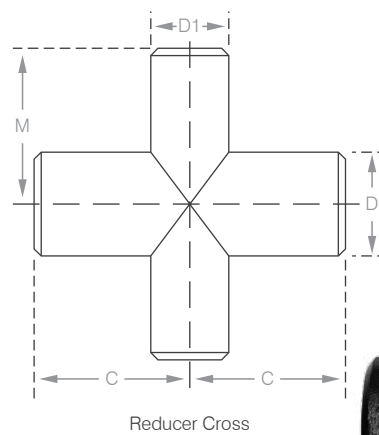

# Reducers

## SD-BRT & SD-BRC

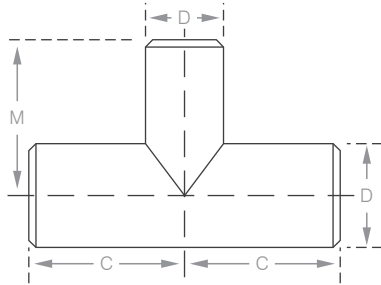

Reducer Tee

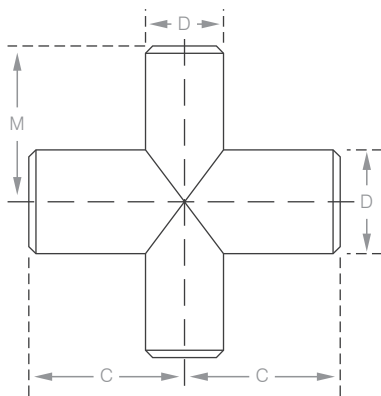

Reducer Cross



Nominal Pipe Size	Outside Diameter		Centre to End	
	D mm	D1 mm	C mm	M mm
5 x 3½	141.3	101.6	124	114
5 x 4	141.3	114.3	124	117
6 x 2½	168.3	73.0	143	121
6 x 3	168.3	88.9	143	124
6 x 3½	168.3	101.6	143	127
6 x 4	168.3	114.3	143	130
6 x 5	168.3	141.3	143	137
8 x 3½	219.1	101.6	178	152
8 x 4	219.1	114.3	178	156
8 x 5	219.1	141.3	178	162
8 x 6	219.1	168.3	178	168
10 x 4	273.0	114.3	216	184
10 x 5	273.0	141.3	216	191
10 x 6	273.0	168.3	216	194
10 x 8	273.0	219.1	216	203
12 x 5	323.8	141.3	254	216
12 x 6	323.8	168.3	254	219
12 x 8	323.8	219.1	254	229
12 x 10	323.8	273.0	254	241
14 x 6	355.6	168.3	279	238
14 x 8	355.6	219.1	279	248
14 x 10	355.6	273.0	279	257
14 x 12	355.6	323.8	279	270
16 x 6	406.4	168.3	305	264
16 x 8	406.4	219.1	305	273
16 x 10	406.4	273.0	305	283
16 x 12	406.4	323.8	305	295
16 x 14	406.4	355.6	305	305
18 x 8	457.0	219.1	343	298
18 x 10	457.0	273.0	343	308
18 x 12	457.0	323.8	343	321
18 x 14	457.0	355.6	343	330
18 x 16	457.0	406.4	343	330
20 x 8	508.0	219.1	381	324
20 x 10	508.0	273.0	381	333
20 x 12	508.0	323.8	381	346
20 x 14	508.0	355.6	381	356
20 x 16	508.0	406.4	381	356
20 x 18	508.0	457.0	381	368
22 x 10	559.0	273.0	419	359
22 x 12	559.0	323.8	419	371
22 x 14	559.0	355.6	419	381
22 x 16	559.0	406.4	419	381
22 x 18	559.0	457.0	419	394
22 x 20	559.0	508.0	419	406
24 x 10	610.0	273.0	432	384
24 x 12	610.0	323.8	432	397
24 x 14	610.0	355.6	432	406

(Cont.)

# Reducers

## SD-BRT & SD-BRC

Nominal Pipe Size Inch	Outside Diameter		Centre to End	
	D mm	D1 mm	C mm	M mm
24 x 16	610.0	406.4	432	406
24 x 18	610.0	457.0	432	419
24 x 20	610.0	508.0	432	432
24 x 22	610.0	559.0	432	432
26 x 12	660.0	323.8	495	422
26 x 14	660.0	355.6	495	432
26 x 16	660.0	406.4	495	432
26 x 18	660.0	457.0	495	444
26 x 20	660.0	508.0	495	457
26 x 22	660.0	559.0	495	470
26 x 24	660.0	610.0	495	483
28 x 12	711.0	323.8	521	448
28 x 14	711.0	355.6	521	457
28 x 16	711.0	406.4	521	457
28 x 18	711.0	457.0	521	470
28 x 20	711.0	508.0	521	483
28 x 22	711.0	559.0	521	495
28 x 24	711.0	610.0	521	508
28 x 26	711.0	660.0	521	521
30 x 10	762.0	273.0	559	460
30 x 12	762.0	323.8	559	473
30 x 14	762.0	355.6	559	483
30 x 16	762.0	406.4	559	483
30 x 18	762.0	457.0	559	495
30 x 20	762.0	508.0	559	508
30 x 22	762.0	559.0	559	521
30 x 24	762.0	610.0	559	533
30 x 26	762.0	660.0	559	546
30 x 28	762.0	711.0	559	546
32 x 14	813.0	355.6	597	508
32 x 16	813.0	406.4	597	508
32 x 18	813.0	457.0	597	521
32 x 20	813.0	508.0	597	533
32 x 22	813.0	559.0	597	546
32 x 24	813.0	610.0	597	559
32 x 26	813.0	660.0	597	572
32 x 28	813.0	711.0	597	572
32 x 30	813.0	762.0	597	584
34 x 16	864.0	406.4	635	533
34 x 18	864.0	457.0	635	546
34 x 20	864.0	508.0	635	559
34 x 22	864.0	559.0	635	572
34 x 24	864.0	610.0	635	584
34 x 26	864.0	660.0	635	597
34 x 28	864.0	711.0	635	597
34 x 30	864.0	762.0	635	610
34 x 32	864.0	813.0	635	622

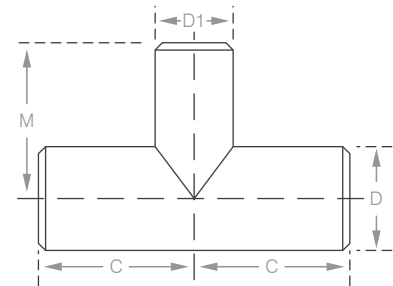

Reducer Tee

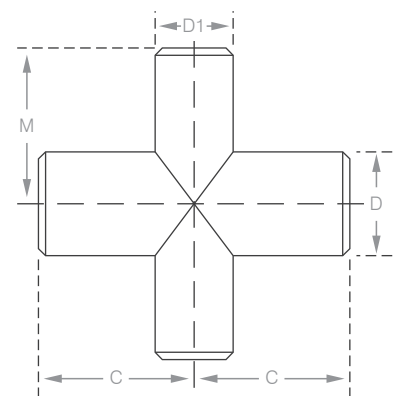

Reducer Cross



# Reducers

## SD-BCOR & SD-BECR

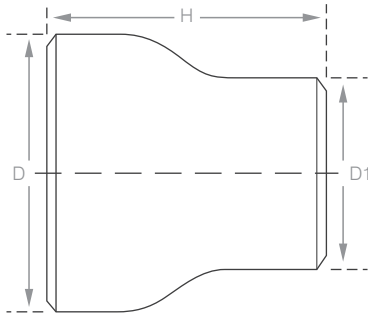

Concentric Reducer



### Concentric Reducer: SD-BCOR Eccentric Reducer: SD-BECR

#### Functions:

A reducer is a fitting that can be used to connect between two different sizes of pipes. A concentric reducer shapes like a cone where eccentric reducer has an edge which is parallel to the joining pipe, this parallel edge outcomes in the two pipes having balanced centre lines.

#### Material:

ASTM A234 Grade WPB

#### Dimension:

ASME B16.9

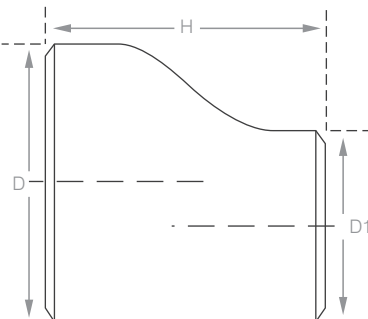

Eccentric Reducer



Nominal Pipe Size	Outside Diameter		End to End
	D mm	D1 mm	H mm
3/4 x 3/8	26.7	17.3	38
3/4 x 1/2	26.7	21.3	38
1 x 1/2	33.4	21.3	51
1 x 3/4	33.4	26.7	51
1 1/4 x 1/2	42.2	21.3	51
1 1/4 x 3/4	42.2	26.7	51
1 1/4 x 1	42.2	33.4	51
1 1/2 x 1/2	48.3	21.3	64
1 1/2 x 3/4	48.3	26.7	64
1 1/2 x 1	48.3	33.4	64
1 1/2 x 1 1/4	48.3	42.2	64
2 x 3/4	60.3	26.7	76
2 x 1	60.3	33.4	76
2 x 1 1/4	60.3	42.2	76
2 x 1 1/2	60.3	48.3	76
2 1/2 x 1	73.0	33.4	89
2 1/2 x 1 1/4	73.0	42.2	89
2 1/2 x 1 1/2	73.0	48.3	89
2 1/2 x 2	73.0	60.3	89
3 x 1 1/4	88.9	42.2	89
3 x 1 1/2	88.9	48.3	89
3 x 2	88.9	60.3	89
3 x 2 1/2	88.9	73.0	89
3 1/2 x 1 1/4	101.6	42.2	102
3 1/2 x 1 1/2	101.6	48.3	102
3 1/2 x 2	101.6	60.3	102
3 1/2 x 2 1/2	101.6	73.0	102
3 1/2 x 3	101.6	88.9	102
4 x 1 1/2	114.3	48.3	102
4 x 2	114.3	60.3	102
4 x 2 1/2	114.3	73.0	102
4 x 3	114.3	88.9	102
4 x 3 1/2	114.3	101.6	102
5 x 2	141.3	60.3	127
5 x 2 1/2	141.3	73.0	127
5 x 3	141.3	88.9	127
5 x 3 1/2	141.3	101.6	127
5 x 4	141.3	114.3	127
6 x 2 1/2	168.3	73.0	140
6 x 3	168.3	88.9	140
6 x 3 1/2	168.3	101.6	140
6 x 4	168.3	114.3	140
6 x 5	168.3	141.3	140
8 x 3 1/2	219.1	101.6	152
8 x 4	219.1	114.3	152
8 x 5	219.1	141.3	152

(Cont.)

# Reducers

## SD-BCOR & SD-BECR

Nominal Pipe Size	Outside Diameter		End to End
	D mm	D1 mm	H mm
8 x 6	219.1	168.3	152
10 x 4	273.0	114.3	178
10 x 5	273.0	141.3	178
10 x 6	273.0	168.3	178
10 x 8	273.0	219.1	178
12 x 5	323.8	141.3	203
12 x 6	323.8	168.3	203
12 x 8	323.8	219.1	203
12 x 10	323.8	273.0	203
14 x 6	355.6	168.3	330
14 x 8	355.6	219.1	330
14 x 10	355.6	273.0	330
14 x 12	355.6	323.8	330
16 x 8	406.4	219.1	356
16 x 10	406.4	273.0	356
16 x 12	406.4	323.8	356
16 x 14	406.4	355.6	356
18 x 10	457.0	273.0	381
18 x 12	457.0	323.8	381
18 x 14	457.0	355.6	381
18 x 16	457.0	406.4	381
20 x 12	508.0	323.8	508
20 x 14	508.0	355.6	508
20 x 16	508.0	406.4	508
20 x 18	508.0	457.0	508
22 x 14	559.0	355.4	508
22 x 16	559.0	406.4	508
22 x 18	559.0	457.0	508
22 x 20	559.0	508.0	508
24 x 16	610.0	406.4	508
24 x 18	610.0	457.0	508
24 x 20	610.0	508.0	508
24 x 22	610.0	559.0	508
26 x 18	660.0	457.0	610
26 x 20	660.0	508.0	610
26 x 22	660.0	559.0	610
26 x 24	660.0	610.0	610
28 x 18	711.0	457.0	610
28 x 20	711.0	508.0	610
28 x 24	711.0	610.0	610
28 x 26	711.0	660.0	610
30 x 20	762.0	508.0	610
30 x 24	762.0	610.0	610
30 x 26	762.0	660.0	610
30 x 28	762.0	711.0	610
32 x 24	813.0	610.0	610

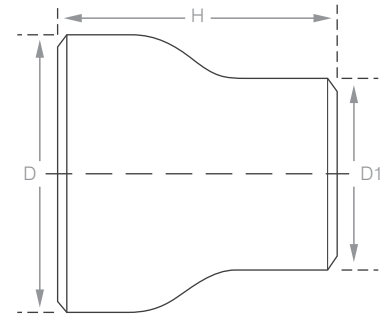

Concentric Reducer

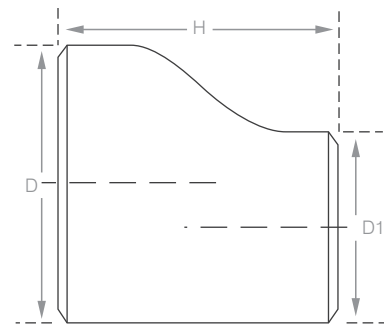

Eccentric Reducer



(Cont.)

# Reducers

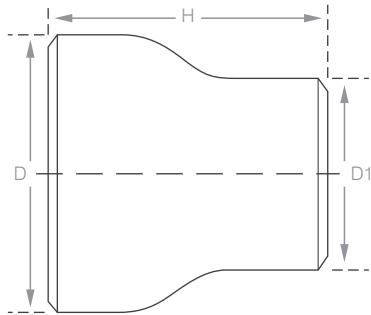

Concentric Reducer

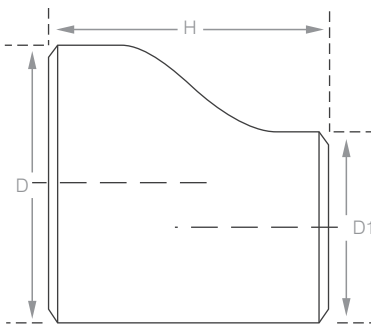

Eccentric Reducer



## SD-BCOR & SD-BECR

Nominal Pipe Size	Outside Diameter		End to End
	D mm	D1 mm	H mm
32 x 26	813.0	660.0	610
32 x 28	813.0	711.0	610
32 x 30	813.0	762.0	610
34 x 24	864.0	610.0	610
34 x 26	864.0	660.0	610
34 x 30	864.0	762.0	610
34 x 32	864.0	813.0	610
36 x 24	914.0	610.0	610
36 x 26	914.0	660.0	610
36 x 30	914.0	762.0	610
36 x 32	914.0	813.0	610
36 x 34	914.0	864.0	610
38 x 26	965.0	660.0	610
38 x 28	965.0	711.0	610
38 x 30	965.0	762.0	610
38 x 32	965.0	813.0	610
38 x 34	965.0	864.0	610
38 x 36	965.0	914.0	610
40 x 30	1016.0	762.0	610
40 x 32	1016.0	813.0	610
40 x 34	1016.0	864.0	610
40 x 36	1016.0	914.0	610
40 x 38	1016.0	965.0	610
42 x 30	1067.0	762.0	610
42 x 32	1067.0	813.0	610
42 x 34	1067.0	864.0	610
42 x 36	1067.0	914.0	610
42 x 38	1067.0	965.0	610
42 x 40	1067.0	1016.0	610
44 x 36	1118.0	914.0	610
44 x 38	1118.0	965.0	610
44 x 40	1118.0	1016.0	610
44 x 42	1118.0	1067.0	610
46 x 38	1168.0	965.0	711
46 x 40	1168.0	1016.0	711
46 x 42	1168.0	1067.0	711
46 x 44	1168.0	1118.0	711
48 x 40	1219.0	1016.0	711
48 x 42	1219.0	1067.0	711
48 x 44	1219.0	1118.0	711
48 x 46	1219.0	1168.0	711

# Reducers

## Reducing Elbow 90°:

SD-BRE 90

Nominal Pipe Size Inch	Outside Diameter		Centre to End
	D mm	D1 mm	A mm
2 x 1	60.3	33.4	76
2 x 1¼	60.3	42.2	76
2 x 1½	60.3	48.3	76
2½ x 1¼	73.0	42.2	95
2½ x 1½	73.0	48.3	95
2½ x 2	73.0	60.3	95
3 x 1½	88.9	48.3	114
3 x 2	88.9	60.3	114
3 x 2½	88.9	73.0	114
3½ x 2	101.6	60.3	133
3½ x 2½	101.6	73.0	133
3½ x 3	101.6	88.9	133
4 x 2	114.3	60.3	152
4 x 2½	114.3	73.0	152
4 x 3	114.3	88.9	152
4 x 3½	114.3	101.6	152
5 x 2½	141.3	73.0	190
5 x 3	141.3	88.9	190
5 x 3½	141.3	101.6	190
5 x 4	141.3	114.3	190
6 x 3	168.3	88.9	229
6 x 3½	168.3	101.6	229
6 x 4	168.3	114.3	229
6 x 5	168.3	141.3	229
8 x 4	219.1	114.3	305
8 x 5	219.1	141.3	305
8 x 6	219.1	168.3	305
10 x 5	273.0	141.3	381
10 x 6	273.0	168.3	381
10 x 8	273.0	219.1	381
12 x 6	323.8	168.3	457

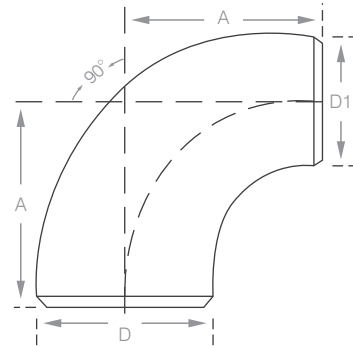

### Functions:

90° Reducing elbow is to change direction or flow in a piping system from one size to another size. The Reducing Elbows have got different size openings on both the end and hence can fit into two different pipes of varying end openings.

### Material:

ASTM A234 Grade WPB

### Dimension:

ASME B16.9 & B16.28



(Cont.)

# Reducers

## SD-BRE 90

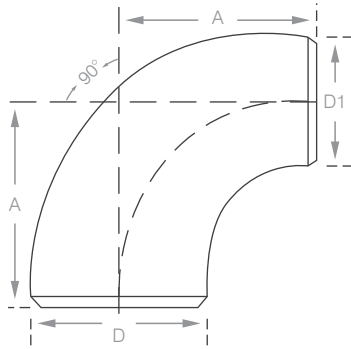

Nominal Pipe Size	Outside Diameter		Centre to End
	D mm	D1 mm	A mm
12 x 8	323.8	219.1	457
12 x 10	323.8	273.0	457
14 x 8	355.6	219.1	533
14 x 10	355.6	273.0	533
14 x 12	355.6	323.8	533
16 x 10	406.4	273.0	610
16 x 12	406.4	323.8	610
16 x 14	406.4	355.6	610
18 x 10	457.0	273.0	686
18 x 12	457.0	323.8	686
18 x 14	457.0	355.6	686
18 x 16	457.0	406.4	686
20 x 10	508.0	273.0	762
20 x 12	508.0	323.8	762
20 x 14	508.0	355.6	762
20 x 16	508.0	406.4	762
20 x 18	508.0	457.0	762
24 x 12	610.0	323.8	914
24 x 14	610.0	355.6	914
24 x 16	610.0	406.4	914
24 x 18	610.0	457.0	914
24 x 20	610.0	508.0	914
24 x 22	610.0	559.0	914

# Bends

## Long Radius Bend 180°:

SD-BLRB 180

Nominal Pipe Size Inch	Outside Diameter D mm	Centre to Centre O mm	Back to Face K mm
1/2	21.3	76	48
3/4	26.7	76	51
1	33.4	76	56
1 1/4	42.2	95	70
1 1/2	48.3	114	83
2	60.3	152	106
2 1/2	73.0	190	132
3	88.9	229	159
4	114.3	305	210
5	141.3	381	262
6	168.3	457	313
8	219.1	610	414
10	273.0	762	518
12	323.8	914	619
14	355.6	1067	711
16	406.4	1219	813
18	457.0	1372	914
20	508.0	1524	1016
22	559.0	1676	1118
24	610.0	1829	1219

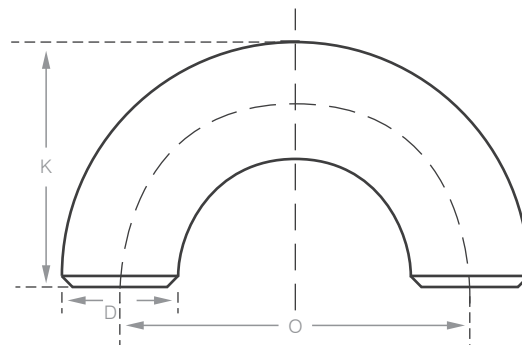

### Functions:

The function of a 180° return bend is to change direction of flow through 180°. The long radius type has a centre to centre dimension double the matching 90° long radius elbow. The primary application for this fitting is in heater coils, heat exchangers and boilers etc.

### Material:

ASTM A234 Grade WPB

### Dimension:

ASME B16.9



# Bends

## Short Radius Bend 180°:

### SD-BSRB 180

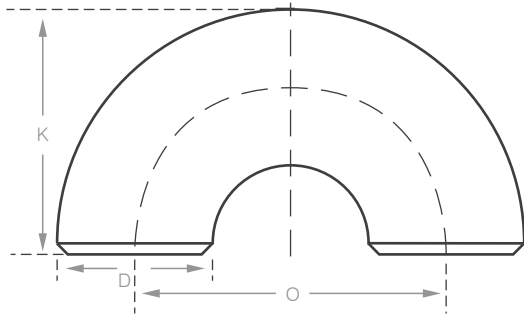

#### Functions:

The function of a 180° return bend is to change direction of flow through 180°. The short radius type has a centre to centre dimension double the matching 90° short radius elbow. The short radius bend is less in cost and space consumption than long radius bend. The primary application for this fitting is in heater coils, heat exchangers and boilers etc.

#### Material:

ASTM A234 Grade WPB

#### Dimension:

ASME B16.9

Nominal Pipe Size	Outside Diameter D	Centre to Centre O	Back to Face K
Inch	mm	mm	mm
1	33.4	51	41
1¼	42.2	64	52
1½	48.3	76	62
2	60.3	102	81
2½	73.0	127	100
3	88.9	152	121
3½	101.6	178	140
4	114.3	203	159
5	141.3	254	197
6	168.3	305	237
8	219.1	406	313
10	273.0	508	391
12	323.8	610	467
14	355.6	711	533
16	406.4	813	610
18	457.0	914	686
20	508.0	1016	762
22	559.0	1118	838
24	610.0	1219	914



# Cap

## End Cap:

SD-BCP

Nominal Pipe Size	Outside Diameter D mm	Length
		E mm
Inch		
1/2	21.3	25
3/4	26.7	25
1	33.4	38
1 1/4	42.2	38
1 1/2	48.3	38
2	60.3	38
2 1/2	73.0	38
3	88.9	51
3 1/2	101.6	64
4	114.3	64
5	141.3	76
6	168.3	89
8	219.1	102
10	273.0	127
12	323.8	152
14	355.6	165
16	406.4	178
18	457.0	203
20	508.0	229
22	559.0	254
24	610.0	267
26	660.0	267
28	711.0	267
30	762.0	267
32	813.0	267
34	864.0	267
36	914.0	267
38	965.0	305
40	1016.0	305
42	1067.0	305
44	1118.0	343
46	1168.0	343
48	1219.0	343

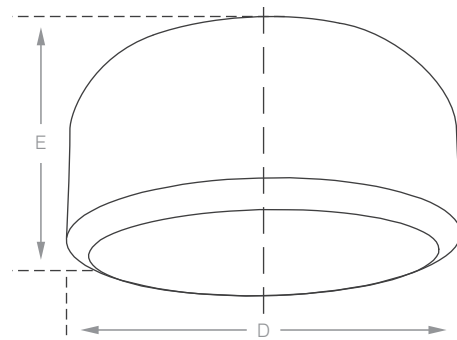

### Functions:

The function of an end cap is to block off the end of a line in piping systems. This is achieved by placing the end cap over the open line and welding around the joint.

### Material:

ASTM A234 Grade WPB

### Dimension:

ASME B16.9





# Flanges

## Description:

### Introduction

Flanges are mainly used to connect valves, pumps and pipes to make a complete piping system. Flanges are classified into three types based on faces, Raised Face (RF), Flat Face (FF) and Ring-Type Joint Face (RTJ). The most commonly used type is Raised Face flange. Flanges can be connected to the piping system either welded or screwed. Flanged joints are fixed by bolting together, with a gasket in between where as required.

### Material

The material specification is totally in compliance with ASTM A105. This standard covers forged carbon steel piping components to use in ambient and high temperature service in pressure systems.



### Dimensions

Flanges are manufactured in accordance with the specification conforms to the dimensions & tolerance given in the international standards ASME B16.5 & BS 4504, BS EN 1092-1.

### Chemical Requirements (in %)

C	Mn	P	S	Si	Cr	Mb	Ni	Cu	V
Max		Max	Max	Min	Max	Max	Max	Max	Max
0.35	0.6-1.05	0.035	0.04	0.1-0.35	0.30	0.12	0.40	0.40	0.08

### Mechanical Requirements

Tensile Strength	Yield Strength	Elongation
Min	Min	Min
70,000 psi (485 MPa)	36,000 psi (250 MPa)	22%

# Flanges

## Blind Flange:

SD-BF 150

Nominal Pipe Size	Outer Diameter	Thickness (Min)	Raised Face	No. of Holes	PCD	Dia. of Bolt holes	Suitable bolt dia.
DN Inch	OD mm	t mm	G mm		K mm	D Inch	Inch
1/2	90	11.2	34.9	4	60.3	5/8	1/2
3/4	100	12.7	42.9	4	69.9	5/8	1/2
1	110	14.3	50.8	4	79.4	5/8	1/2
1 1/4	115	15.9	63.5	4	88.9	5/8	1/2
1 1/2	125	17.5	73.0	4	98.4	5/8	1/2
2	150	19.1	92.1	4	120.7	3/4	5/8
2 1/2	180	22.3	104.8	4	139.7	3/4	5/8
3	190	23.9	127.0	4	152.4	3/4	5/8
3 1/2	215	23.9	139.7	8	177.8	3/4	5/8
4	230	23.9	157.2	8	190.5	3/4	5/8
5	255	23.9	185.7	8	215.9	7/8	3/4
6	280	25.4	215.9	8	241.3	7/8	3/4
8	345	28.6	269.9	8	298.5	7/8	3/4
10	405	30.2	323.8	12	362.0	1	7/8
12	485	31.8	381.0	12	431.8	1	7/8
14	535	35.0	412.8	12	476.3	1 1/8	1
16	595	36.6	469.9	16	539.8	1 1/8	1
18	635	39.7	533.4	16	577.9	1 1/4	1 1/8
20	700	42.9	584.2	20	635.0	1 1/4	1 1/8
24	815	47.7	692.2	20	749.3	1 3/8	1 1/4

### Functions:

The Blind flange is manufactured using a bore (a round steel plate) with appropriate bolt holes. It is a highly stressed flange, however, most of the stresses are near the centre. It is suitable for high pressure applications. Blind flange is commonly used to close off end for piping system and pressure vessel openings.

### Material:

ASTM A105, Carbon Steel

### Dimension:

ASME B16.5, Class 150

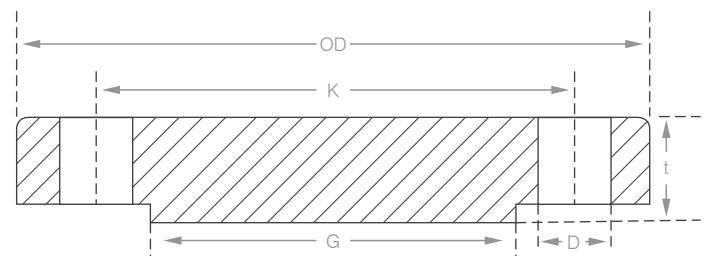

# Flanges

## Blind Flange:

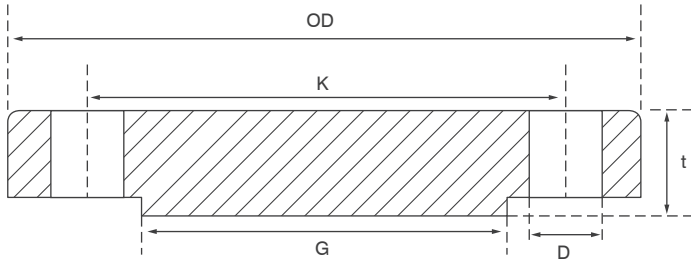

### Material:

ASTM A105, Carbon Steel

### Dimension:

ASME B16.5, Class 300

### SD-BF 300

Nominal Pipe Size DN Inch	Outside Diameter OD mm	Thickness (Min) t mm	Raised Face G mm	No. of Holes	PCD K mm	Dia. of Bolt holes D Inch	Suitable bolt dia. Inch
1/2	95	12.7	34.9	4	66.7	5/8	1/2
3/4	115	14.3	42.9	4	82.6	3/4	5/8
1	125	15.9	50.8	4	88.9	3/4	5/8
1 1/4	135	17.5	63.5	4	98.4	3/4	5/8
1 1/2	155	19.1	73.0	4	114.3	7/8	3/4
2	165	20.7	92.1	8	127.0	3/4	5/8
2 1/2	190	23.9	104.8	8	149.2	7/8	3/4
3	210	27.0	127.0	8	168.3	7/8	3/4
3 1/2	230	28.6	139.7	8	184.2	7/8	3/4
4	255	30.2	157.2	8	200.0	7/8	3/4
5	280	33.4	185.7	8	235.0	7/8	3/4
6	320	35.0	215.9	12	269.9	7/8	3/4
8	380	39.7	269.9	12	330.2	1	7/8
10	445	46.1	323.8	16	387.4	1 1/8	1
12	520	49.3	381.0	16	450.8	1 1/4	1 1/8
14	585	52.4	412.8	20	514.4	1 1/4	1 1/8
16	650	55.6	469.9	20	571.5	1 3/8	1 1/4
18	710	58.8	533.4	24	628.6	1 3/8	1 1/4
20	775	62.0	584.2	24	685.8	1 3/8	1 1/4
24	915	68.3	692.2	24	812.8	1 5/8	1 1/2

# Flanges

## Slip-On Flange:

### Functions:

A Slip-On Flange is slightly larger than the outer diameter of the pipe it is to be used with. The pipe is slipped into the Flange prior to welding both inside and outside. It is easy to install and weld, therefore significantly reduce fabrication cost.

### Material:

ASTM A105, Carbon Steel

### Dimension:

ASME B16.5, Class 150

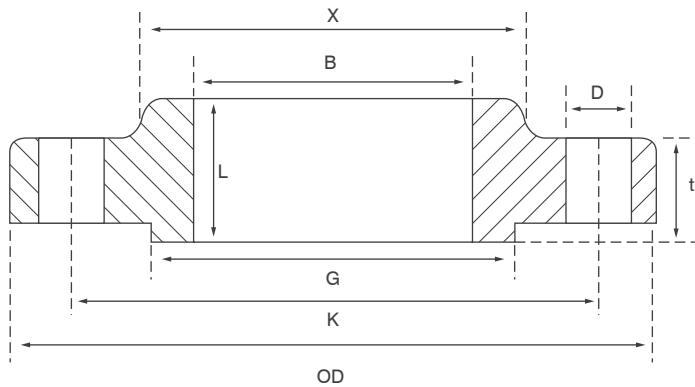

### SD-SOF-RF 150

Nominal Pipe Size DN Inch	Outer Diameter OD mm	Thickness (Min) t mm	Raised Face G mm	Dia. of Hub X mm	Bore B mm	Length thru Hub L mm	No. of Holes	PCD K mm	Dia. of Bolt holes D Inch	Suitable bolt dia. Inch
1/2	90	11.2	34.9	30	22.2	14	4	60.3	5/8	1/2
3/4	100	12.7	42.9	38	27.7	14	4	69.9	5/8	1/2
1	110	14.3	50.8	49	34.5	16	4	79.4	5/8	1/2
1 1/4	115	15.9	63.5	59	43.2	19	4	88.9	5/8	1/2
1 1/2	125	17.5	73.0	65	49.5	21	4	98.4	5/8	1/2
2	150	19.1	92.1	78	61.9	24	4	120.7	3/4	5/8
2 1/2	180	22.3	104.8	90	74.6	27	4	139.7	3/4	5/8
3	190	23.9	127.0	108	90.7	29	4	152.4	3/4	5/8
3 1/2	215	23.9	139.7	122	103.4	30	8	177.8	3/4	5/8
4	230	23.9	157.2	135	116.1	32	8	190.5	3/4	5/8
5	255	23.9	185.7	164	143.8	35	8	215.9	7/8	3/4
6	280	25.4	215.9	192	170.7	38	8	241.3	7/8	3/4
8	345	28.6	269.9	246	221.5	43	8	298.5	7/8	3/4
10	405	30.2	323.8	305	276.2	48	12	362.0	1	7/8
12	485	31.8	381.0	365	327.0	54	12	431.8	1	7/8
14	535	35.0	412.8	400	359.2	56	12	476.3	1 1/8	1
16	595	36.6	469.9	457	410.5	62	16	539.8	1 1/8	1
18	635	39.7	533.4	505	461.8	67	16	577.9	1 1/4	1 1/8
20	700	42.9	584.2	559	513.1	71	20	635.0	1 1/4	1 1/8
24	815	47.7	692.2	663	616.0	81	20	749.3	1 3/8	1 1/4

# Flanges

## Slip-On Flange:

SD-SOF-RF 300

Nominal Pipe Size	Outer Diameter	Thickness (Min)	Raised Face	Dia. of Hub	Bore	Length thru Hub	No. of Holes	PCD	Dia. of Bolt holes	Suitable bolt dia.
DN Inch	OD mm	t mm	G mm	X mm	B mm	L mm		K mm	D Inch	Inch
1/2	95	12.7	34.9	38	22.2	21	4	66.7	5/8	1/2
3/4	115	14.3	42.9	48	27.7	24	4	82.6	3/4	5/8
1	125	15.9	50.8	54	34.5	25	4	88.9	3/4	5/8
1 1/4	135	17.5	63.5	64	43.2	25	4	98.4	3/4	5/8
1 1/2	155	19.1	73.0	70	49.5	29	4	114.3	7/8	3/4
2	165	20.7	92.1	84	61.9	32	8	127.0	3/4	5/8
2 1/2	190	23.9	104.8	100	74.6	37	8	149.2	7/8	3/4
3	210	27.0	127.0	117	90.7	41	8	168.3	7/8	3/4
3 1/2	230	28.6	139.7	133	103.4	43	8	184.2	7/8	3/4
4	255	30.2	157.2	146	116.1	46	8	200.0	7/8	3/4
5	280	33.4	185.7	178	143.8	49	8	235.0	7/8	3/4
6	320	35.0	215.9	206	170.7	51	12	269.9	7/8	3/4
8	380	39.7	269.9	260	221.5	60	12	330.2	1	7/8
10	445	46.1	323.8	321	276.2	65	16	387.4	1 1/8	1
12	520	49.3	381.0	375	327.0	71	16	450.8	1 1/4	1 1/8
14	585	52.4	412.8	425	359.2	75	20	514.4	1 1/4	1 1/8
16	650	55.6	469.9	483	410.5	81	20	571.5	1 3/8	1 1/4
18	710	58.8	533.4	533	461.8	87	24	628.6	1 3/8	1 1/4
20	775	62.0	584.2	587	513.1	94	24	685.8	1 3/8	1 1/4
24	915	68.3	692.2	702	616.0	105	24	812.8	1 5/8	1 1/2

### Material:

ASTM A105, Carbon Steel

### Dimension:

ASME B16.5, Class 300

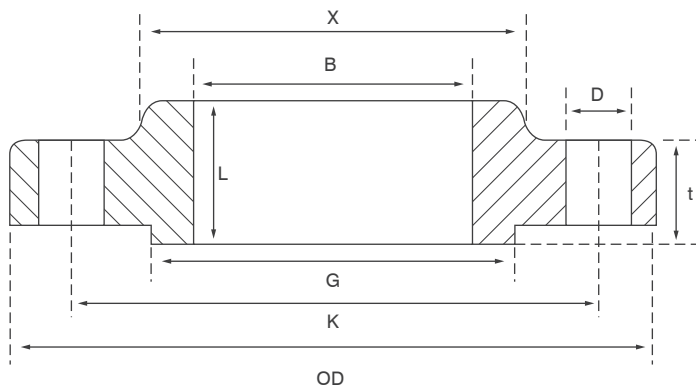

# Flanges

## Weld Neck Flange:

### Functions:

A Welded flange is bored to match the inside diameter of the mating pipe or fitting to ensure uninterrupted flow. This prevents turbulence at the joint and reduces erosion. It also provides excellent stress distribution through the tapered hub and is easily radiographed for flaw detection. It is welded to a pipe or fitting with a single full penetration.

### Material:

ASTM A105, Carbon Steel

### Dimension:

ASME B16.5, Class 150

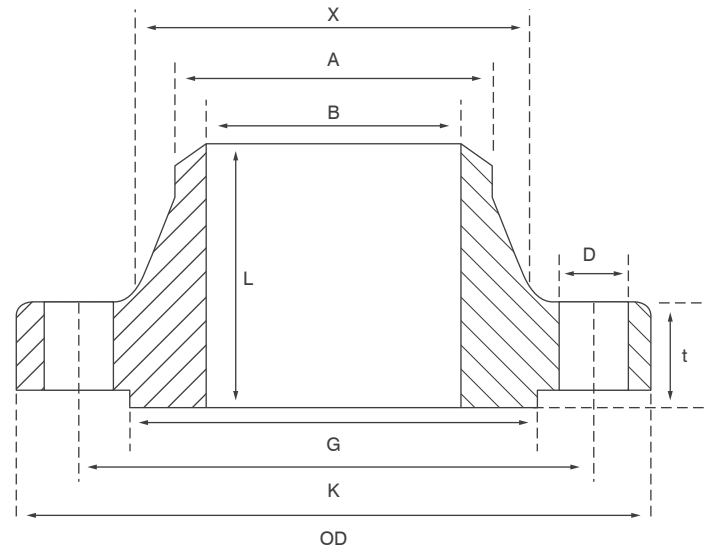

## SD-WF-RF 150

Nominal Pipe Size	Outer Diameter	Thickness (Min)	Raised Face	Dia. of Hub	Bore	OD of Weld Neck	Length thru Hub	No. of Holes	PCD	Dia. of Bolt holes	Suitable bolt dia.
DN Inch	OD mm	t mm	G mm	X mm	B mm	A mm	L mm		K mm	D Inch	Inch
1/2	90	11.2	34.9	30	15.8	21.3	46	4	60.3	5/8	1/2
3/4	100	12.7	42.9	38	20.9	26.7	51	4	69.9	5/8	1/2
1	110	14.3	50.8	49	26.6	33.4	54	4	79.4	5/8	1/2
1 1/4	115	15.9	63.5	59	35.1	42.2	56	4	88.9	5/8	1/2
1 1/2	125	17.5	73.0	65	40.9	48.3	60	4	98.4	5/8	1/2
2	150	19.1	92.1	78	52.5	60.3	62	4	120.7	3/4	5/8
2 1/2	180	22.3	104.8	90	62.7	73.0	68	4	139.7	3/4	5/8
3	190	23.9	127.0	108	77.9	88.9	68	4	152.4	3/4	5/8
3 1/2	215	23.9	139.7	122	90.1	101.6	70	8	177.8	3/4	5/8
4	230	23.9	157.2	135	102.3	114.3	75	8	190.5	3/4	5/8
5	255	23.9	185.7	164	128.2	141.3	87	8	215.9	7/8	3/4
6	280	25.4	215.9	192	154.1	168.3	87	8	241.3	7/8	3/4
8	345	28.6	269.9	246	202.7	219.1	100	8	298.5	7/8	3/4
10	405	30.2	323.8	305	254.6	273.0	100	12	362.0	1	7/8
12	485	31.8	381.0	365	304.8	323.8	113	12	431.8	1	7/8
14	535	35.0	412.8	400	-	355.6	125	12	476.3	1 1/8	1
16	595	36.6	469.9	457	-	406.4	125	16	539.8	1 1/8	1
18	635	39.7	533.4	505	-	457.0	138	16	577.9	1 1/4	1 1/8
20	700	42.9	584.2	559	-	508.0	143	20	635.0	1 1/4	1 1/8
24	815	47.7	692.2	663	-	610.0	151	20	749.3	1 3/8	1 1/4

# Flanges

## Weld Neck Flange:

SD-WF-RF 300

Nominal Pipe Size	Outer Diameter	Thickness (Min)	Raised Face	Dia. of Hub	Bore	OD of Weld Neck	Length thru Hub	No. of Holes	PCD	Dia. of Bolt holes	Suitable bolt dia.
DN Inch	OD mm	t mm	G mm	X mm	B mm	A mm	L mm		K mm	D Inch	Inch
1/2	95	12.7	34.9	38	15.8	21.3	51	4	66.7	5/8	1/2
3/4	115	14.3	42.9	48	20.9	26.7	56	4	82.6	3/4	5/8
1	125	15.9	50.8	54	26.6	33.4	60	4	88.9	3/4	5/8
1 1/4	135	17.5	63.5	64	35.1	42.2	64	4	98.4	3/4	5/8
1 1/2	155	19.1	73.0	70	40.9	48.3	67	4	114.3	7/8	3/4
2	165	20.7	92.1	84	52.5	60.3	68	8	127.0	3/4	5/8
2 1/2	190	23.9	104.8	100	62.7	73.0	75	8	149.2	7/8	3/4
3	210	27.0	127.0	117	77.9	88.9	78	8	168.3	7/8	3/4
3 1/2	230	28.6	139.7	133	90.1	101.6	79	8	184.2	7/8	3/4
4	255	30.2	157.2	146	102.3	114.3	84	8	200.0	7/8	3/4
5	280	33.4	185.7	178	128.2	141.3	97	8	235.0	7/8	3/4
6	320	35.0	215.9	206	154.1	168.3	97	12	269.9	7/8	3/4
8	380	39.7	269.9	260	202.7	219.1	110	12	330.2	1	7/8
10	445	46.1	323.8	321	254.6	273.0	116	16	387.4	1 1/8	1
12	520	49.3	381.0	375	304.8	323.8	129	16	450.8	1 1/4	1 1/8
14	585	52.4	412.8	425	-	355.6	141	20	514.4	1 1/4	1 1/8
16	650	55.6	469.9	483	-	406.4	144	20	571.5	1 3/8	1 1/4
18	710	58.8	533.4	533	-	457.0	157	24	628.6	1 3/8	1 1/4
20	775	62.0	584.2	587	-	508.0	160	24	685.8	1 3/8	1 1/4
24	915	68.3	692.2	702	-	610.0	167	24	812.8	1 5/8	1 1/2

### Material:

ASTM A105, Carbon Steel

### Dimension:

ASME B16.5, Class 300

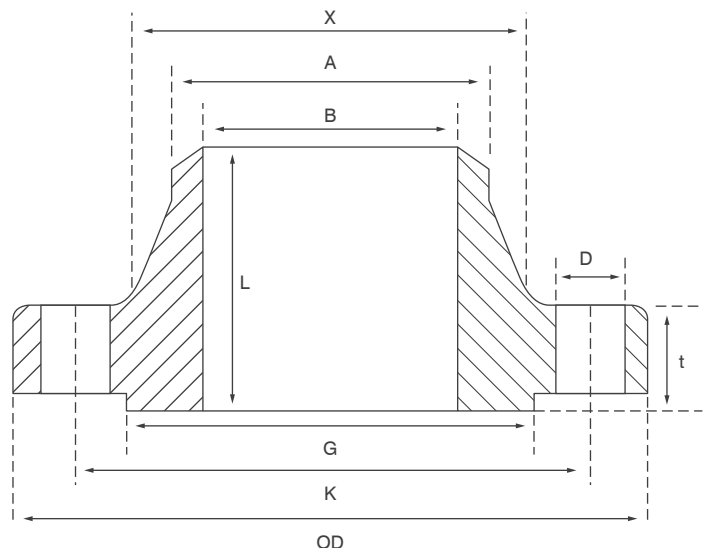



# Flange eliminates the weld for pipe spool



A process of joining pipes, valves, pumps, and so forth to create a piping system by using a flange. It also gives simple access to cleaning, assessment or modification. Flanges are generally welded or screwed.

# Flanges

## Blind Flange:

### Functions:

The Blind flange is manufactured using a bore (a round steel plate) with appropriate bolt holes. It is a highly stressed flange, however, most of the stresses are near the centre. It is suitable for high pressure applications. Blind flange is commonly used to close off end for piping system and pressure vessel openings.

### Material:

ASTM A105, Carbon Steel

### Dimension:

BS 4504 , BS EN 1092-1

### PN Chart:

PN10

SD-BF10

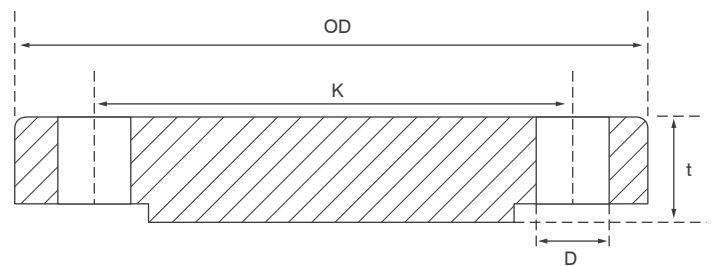

Nominal Size		Outer Dia. OD mm	PCD K mm	Thickness t mm	No. of Holes mm	Hole Dia. D mm	Suitable Thread mm
Inch	mm						
1/2	15	95	65	16	4	14	M12
3/4	20	105	75	18	4	14	M12
1	25	115	85	18	4	14	M12
1 1/4	32	140	100	18	4	18	M16
1 1/2	40	150	110	18	4	18	M16
2	50	165	125	20	4	18	M16
2 1/2	65	185	145	20	4	18	M16
3	80	200	160	20	8	18	M16
4	100	220	180	22	8	18	M16
5	125	250	210	22	8	18	M16
6	150	285	240	24	8	22	M20
8	200	340	295	24	8	22	M20
10	250	395	350	26	12	22	M20
12	300	445	400	26	12	22	M20
14	350	505	460	26	16	22	M20
16	400	565	515	26	16	26	M24
18	450	615	565	28	20	26	M24
20	500	670	620	28	20	26	M24
24	600	780	725	34	20	30	M27



# Flanges

## PN Chart:

PN16

## SD-BF16

Nominal Size		Outer Dia. OD mm	PCD K mm	Thickness t mm	No. of Holes mm	Hole Dia. D mm	Suitable Thread mm
Inch	mm						
1/2	15	95	65	16	4	14	M12
3/4	20	105	75	18	4	14	M12
1	25	115	85	18	4	14	M12
1 1/4	32	140	100	18	4	18	M16
1 1/2	40	150	110	18	4	18	M16
2	50	165	125	18	4	18	M16
2 1/2	65	185	145	18	4	18	M16
3	80	200	160	20	8	18	M16
4	100	220	180	20	8	18	M16
5	125	250	210	22	8	18	M16
6	150	285	240	22	8	22	M20
8	200	340	295	24	12	22	M20
10	250	405	355	26	12	26	M24
12	300	460	410	28	12	26	M24
14	350	520	470	30	16	26	M24
16	400	580	525	32	16	30	M27
18	450	640	585	40	20	30	M27
20	500	715	650	44	20	33	M30
24	600	840	770	54	20	36	M33

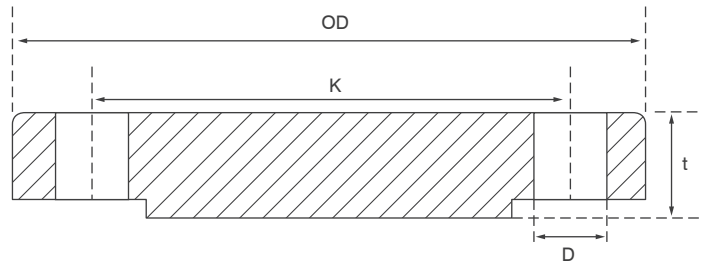

## PN Chart:

PN25

## SD-BF25

Nominal Size		Outer Dia. OD mm	PCD K mm	Thickness t mm	No. of Holes mm	Hole Dia. D mm	Suitable Thread mm
Inch	mm						
1/2	15	95	65	16	4	14	M12
3/4	20	105	75	18	4	14	M12
1	25	115	85	18	4	14	M12
1 1/4	32	140	100	18	4	18	M16
1 1/2	40	150	110	18	4	18	M16
2	50	165	125	20	4	18	M16
2 1/2	65	185	145	22	8	18	M16
3	80	200	160	24	8	18	M16
4	100	235	190	24	8	22	M20
5	125	270	220	26	8	26	M24
6	150	300	250	28	8	26	M24
8	200	360	310	30	12	26	M24
10	250	425	370	32	12	30	M27
12	300	485	430	34	16	30	M27
14	350	555	490	38	16	33	M30
16	400	620	550	40	16	36	M33
18	450	670	600	50	20	36	M33
20	500	730	660	51	20	36	M33
24	600	845	770	66	20	39	M36



\* Note: There can be minor dimensional variations between both dimension standards.  
 \* SHIELD reserves the right to change the contents without notice.

# Flanges

## Slip-On Flange:

### Functions:

A Slip-On Flange is slightly larger than the outer diameter of the pipe it is to be used with. The pipe is slipped into the Flange prior to welding both inside and outside. It is easy to install and weld, therefore significantly reduce fabrication cost.

### Material:

ASTM A105, Carbon Steel

### Dimension:

BS 4504 , BS EN 1092-1

### PN Chart:

PN10

SD-SOF-RF10

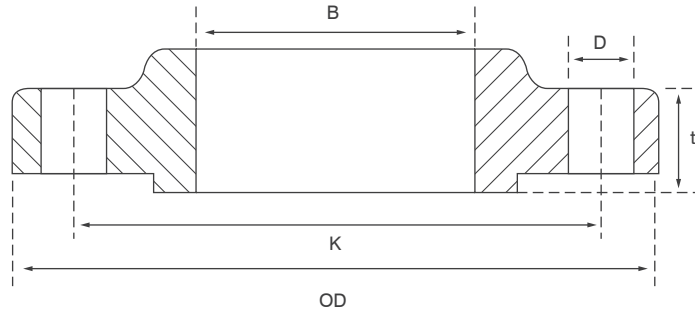

Nominal Size		Outer Dia. OD mm	PCD K mm	Thickness t mm	Bore B mm	No. of Holes mm	Hole Dia. D mm	Suitable Thread mm
Inch	mm							
1/2	15	95	65	16	22.0	4	14	M12
3/4	20	105	75	16	27.5	4	14	M12
1	25	115	85	18	34.5	4	14	M12
1 1/4	32	140	100	18	43.5	4	18	M16
1 1/2	40	150	110	18	49.5	4	18	M16
2	50	165	125	18	61.5	4	18	M16
2 1/2	65	185	145	18	77.5	4	18	M16
3	80	200	160	20	90.5	8	18	M16
4	100	220	180	20	116.0	8	18	M16
5	125	250	210	22	141.5	8	18	M16
6	150	285	240	22	170.5	8	22	M20
8	200	340	295	24	221.5	8	22	M20
10	250	395	350	26	276.5	12	22	M20
12	300	445	400	26	327.5	12	22	M20
14	350	505	460	26	359.5	16	22	M20
16	400	565	515	26	411.0	16	26	M24
18	450	615	565	28	462.0	20	26	M24
20	500	670	620	28	513.5	20	26	M24
24	600	780	725	30	616.5	20	30	M27



# Flanges

## PN Chart:

PN16

SD-SOF-RF16

Nominal Size		Outer Dia. OD mm	PCD K mm	Thickness t mm	Bore B mm	No. of Holes mm	Hole Dia. D mm	Suitable Thread mm
Inch	mm							
1/2	15	95	65	16	22.00	4	14	M12
3/4	20	105	75	18	27.50	4	14	M12
1	25	115	85	18	34.50	4	14	M12
1 1/4	32	140	100	18	43.50	4	18	M16
1 1/2	40	150	110	18	49.50	4	18	M16
2	50	165	125	18	61.50	4	18	M16
2 1/2	65	185	145	18	77.50	4	18	M16
3	80	200	160	20	90.50	8	18	M16
4	100	220	180	20	116.00	8	18	M16
5	125	250	210	22	141.50	8	18	M16
6	150	285	240	22	170.50	8	22	M20
8	200	340	295	24	221.50	12	22	M20
10	250	405	355	26	276.50	12	26	M24
12	300	460	410	28	327.50	12	26	M24
14	350	520	470	30	359.00	16	26	M24
16	400	580	525	32	411.00	16	30	M27
18	450	640	585	34	462.00	20	30	M27
20	500	715	650	36	513.50	20	33	M30
24	600	840	770	40	616.50	20	36	M33

## PN Chart:

PN25

SD-SOF-RF25

Nominal Size		Outer Dia. OD mm	PCD K mm	Thickness t mm	Bore B mm	No. of Holes mm	Hole Dia. D mm	Suitable Thread mm
Inch	mm							
1/2	15	95	65	16	22.00	4	14	M12
3/4	20	105	75	18	27.50	4	14	M12
1	25	115	85	18	34.50	4	14	M12
1 1/4	32	140	100	18	43.50	4	18	M16
1 1/2	40	150	110	18	49.50	4	18	M16
2	50	165	125	20	61.50	4	18	M16
2 1/2	65	185	145	22	77.50	8	18	M16
3	80	200	160	24	90.50	8	18	M16
4	100	235	190	24	116.00	8	22	M20
5	125	270	220	26	141.50	8	26	M24
6	150	300	250	28	170.50	8	26	M24
8	200	360	310	30	221.50	12	26	M24
10	250	425	370	32	276.50	12	30	M27
12	300	485	430	34	327.50	16	30	M27
14	350	555	490	38	359.50	16	33	M30
16	400	620	550	40	411.00	16	36	M33
18	450	670	600	42	462.00	20	36	M33
20	500	730	660	48	513.50	20	36	M33
24	600	845	770	48	616.50	20	39	M36



\* Note: There can be minor dimensional variations between both dimension standards.  
 \* SHIELD reserves the right to change the contents without notice.

# Flanges

## Weld Neck Flange:

### Functions:

A Welded flange is bored to match the inside diameter of the mating pipe or fitting to ensure uninterrupted flow. This prevents turbulence at the joint and reduces erosion. It also provides excellent stress distribution through the tapered hub and is easily radiographed for flaw detection. It is welded to a pipe or fitting with a single full penetration.

### Material:

ASTM A105, Carbon Steel

### Dimension:

BS 4504, BS EN 1092-1

### PN Chart:

PN10

SD-WF-RF10

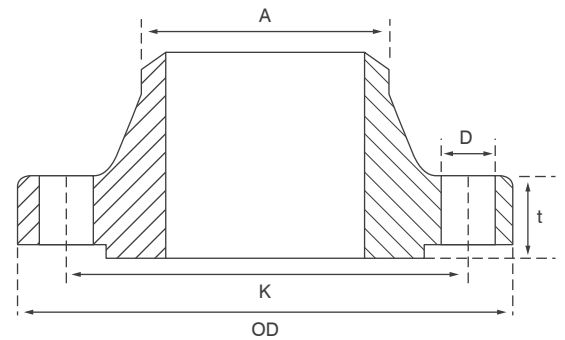

Nominal Size		Outer Dia. OD mm	PCD K mm	Thickness t mm	OD of Weld Neck A mm	No. of Holes	Hole Dia. D mm	Suitable Thread
Inch	mm							
1/2	15	95	65	16	21.30	4	14	M12
3/4	20	105	75	18	26.90	4	14	M12
1	25	115	85	18	33.70	4	14	M12
1 1/4	32	140	100	18	42.40	4	18	M16
1 1/2	40	150	110	18	48.30	4	18	M16
2	50	165	125	18	60.30	4	18	M16
2 1/2	65	185	145	18	76.10	4	18	M16
3	80	200	160	20	88.90	8	18	M16
4	100	220	180	20	114.30	8	18	M16
5	125	250	210	22	139.70	8	18	M16
6	150	285	240	22	168.30	8	22	M20
8	200	340	295	24	219.10	8	22	M20
10	250	395	350	26	273.00	12	22	M20
12	300	445	400	26	323.90	12	22	M20
14	350	505	460	26	355.60	16	22	M20
16	400	565	515	26	406.40	16	26	M24
18	450	615	565	28	457.00	20	26	M24
20	500	670	620	28	508.00	20	26	M24
24	600	780	725	30	610.00	20	30	M27



# Flanges

## PN Chart:

PN16

SD-WF-RF16

Nominal Size		Outer Dia. OD mm	PCD K mm	Thickness t mm	OD of Weld Neck A mm	No. of Holes	Hole Dia. D mm	Suitable Thread
Inch	mm							
1/2	15	95	65	16	21.3	4	14	M12
3/4	20	105	75	18	26.9	4	14	M12
1	25	115	85	18	33.7	4	14	M12
1 1/4	32	140	100	18	42.4	4	18	M16
1 1/2	40	150	110	18	48.3	4	18	M16
2	50	165	125	18	60.3	4	18	M16
2 1/2	65	185	145	18	76.1	4	18	M16
3	80	200	160	20	88.9	8	18	M16
4	100	220	180	20	114.3	8	18	M16
5	125	250	210	22	139.7	8	18	M16
6	150	285	240	22	168.3	8	22	M20
8	200	340	295	24	219.1	12	22	M20
10	250	405	355	26	273.0	12	26	M24
12	300	460	410	28	323.9	12	26	M24
14	350	520	470	30	355.6	16	26	M24
16	400	580	525	32	406.4	16	30	M27
18	450	640	585	34	457.0	20	30	M27
20	500	715	650	36	508.0	20	33	M30
24	600	840	770	36	610.0	20	36	M33



## PN Chart:

PN25

SD-WF-RF25

Nominal Size		Outer Dia. OD mm	PCD K mm	Thickness t mm	OD of Weld Neck A mm	No. of Holes	Hole Dia. D mm	Suitable Thread
Inch	mm							
1/2	15	95	65	16	21.30	4	14	M12
3/4	20	105	75	18	26.90	4	14	M12
1	25	115	85	18	33.70	4	14	M12
1 1/4	32	140	100	18	42.40	4	18	M16
1 1/2	40	150	110	18	48.30	4	18	M16
2	50	165	125	20	60.30	4	18	M16
2 1/2	65	185	145	22	76.10	8	18	M16
3	80	200	160	24	88.90	8	18	M16
4	100	235	190	24	114.30	8	22	M20
5	125	270	220	26	139.70	8	26	M24
6	150	300	250	28	168.30	8	26	M24
8	200	360	310	30	219.10	12	26	M24
10	250	425	370	32	273.00	12	30	M27
12	300	485	430	34	323.90	16	30	M27
14	350	555	490	38	355.60	16	33	M30
16	400	620	550	40	406.40	16	36	M33
18	450	670	600	46	457.00	20	36	M33
20	500	730	660	48	508.00	20	36	M33
24	600	845	770	48	610.00	20	39	M36



\* Note: There can be minor dimensional variations between both dimension standards.  
 \* SHIELD reserves the right to change the contents without notice.



**SHIELD**<sup>TM</sup>  
*Trusted Worldwide*



For further information on any aspect of the SHIELD range of Butt-weld Fittings & Flanges please contact your nearest office.

**UNITED KINGDOM**

Unit 3, Endeavour Drive,  
Basildon-Essex, SS14 3WF,  
United Kingdom.  
Email: [shielduk@shieldglobal.com](mailto:shielduk@shieldglobal.com)  
Tel: +44 1708 377731  
Fax: +44 1708 347637

**MIDDLE EAST & AFRICA**

Jebel Ali Free Zone, Dubai, UAE  
Email: [shieldme@shieldglobal.com](mailto:shieldme@shieldglobal.com)  
Tel: +971 4 881 2070  
Fax: +971 4 881 2198