

Fan Coil Unit Valve Package

Model: SD-VP/9717

Fan coil unit valve package is an innovative and ultra compact valve arrangement that minimize the time and space required to connect the system terminal to distribution pipe. Valve package is a pre-assembled factory tested valve arrangement which gather in a unique item. All the components needed for terminal end unit such as strainer, bypass valve, balancing valve and draincock no need of assembly on site.



Product Specifications:

Working Pressure	PN26
Working Temperature	-10°C - 100°C
Thread	ISO 7 & ISO 228

Fan Coil Unit Valve Package

Product Dimensions:

Fan Coil Unit Valve Package

DN	Dimensions				Silicon Rubber	Coupling	Bush
	A	B	C	D		(2 pcs)	(1 pcs)
15	203	170	105	100	Φ24 x Φ15 x 2.5	9101C-15 x 20-01	9101C-15 ~ 32-02
20	229	184	112	113	Φ30.5 x Φ24 x 2.5	9101C-20 x 25 ~ 25 x 32-1	9101C-15 ~ 32-02
25	271	210	128	130	Φ39 x Φ 30.5 x 2.5	9101C-20 x 25 ~ 25 x 32-01	9101C-15 ~ 32-02

Drawing Specification

No.	Part	Material
1	Coupling	DZR BRass
2	Gasket	PTFE
3	Handle (RED)	Aluminium
4	Ball Valve	DZR BRass
5	Nut	DZR BRass
6	Female Nipple	DZR BRass
7	Handle (BLACK)	Aluminium
8	Connection Piece	DZR BRass
9	Test Points	DZR BRass
10	Ball Valve	DZR BRass
11	Handle (BLUE)	Aluminium
12	Strainer	DZR BRass
13	Bush	DZR BRass

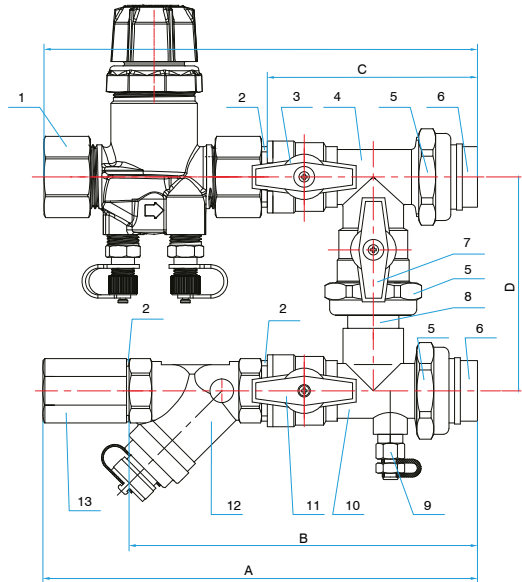

Fan Coil Unit Valve Package

Miscellaneous Data:

1. Ordering Information

Example: SD-VP/9717-20

- SD-VP/9717 is the part number
- (20) Size

2. Contact Information

For further information on any aspect of the SHIELD Valves products please contact below:

MIDDLE EAST & AFRICA	UNITED KINGDOM
Jebel Ali Free Zone, Dubai, UAE P.O Box: 61199 Tel.: +971 4 881 2070 Fax: +971 4 881 2198 Email: shieldme@shielglobal.com	Unit 3, Endeavor Drive, Basildon-Essex, SS3 14WF Tel.: +44 1708 377731 Fax: +44 1708347637 Email: shielduk@shielglobal.com