

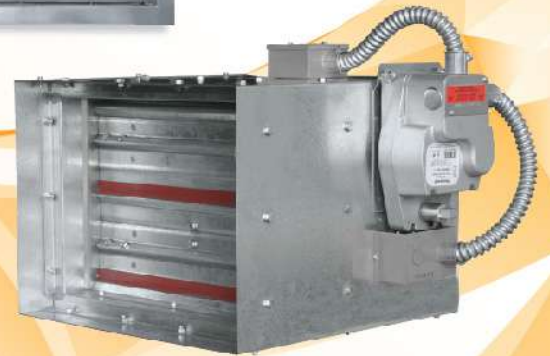

# Dampers (FIRE, SMOKE & HVAC) & Louvers

Caring for Human Life & Property

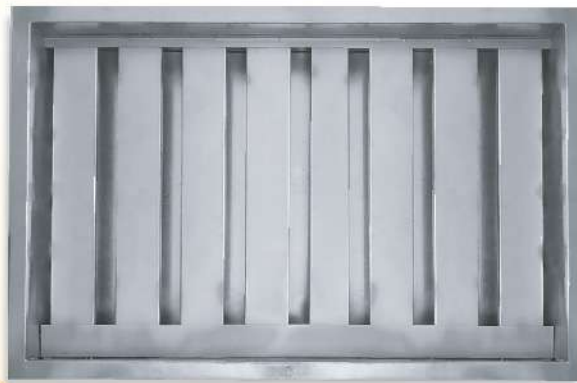





# Contents

<i>i</i>	<b>INTRODUCTION</b>
<b>01</b>	<b>FIRE &amp; SMOKE DAMPERS</b>
<b>02</b>	Curtain Fire Damper
<b>04</b>	Motorized Fire Damper
<b>07</b>	Motorized Combination Fire & Smoke Damper
<b>09</b>	Access Door
<b>11</b>	<b>VOLUME CONTROL DAMPERS</b>
<b>12</b>	Volume Control Damper
<b>15</b>	Round Volume Control Damper
<b>16</b>	Non-Return Damper
<b>16</b>	Pressure Relief Damper
<b>18</b>	<b>LOUVERS</b>
<b>19</b>	Sand Trap Louver
<b>24</b>	Fresh Air Louver



# Introduction

NAFFCO Flow Control provides a complete solution for the HVAC and construction projects, along with the customized system design and supply for the unique projects.

Since its inception, NAFFCO Flow Control has been continuously striving through its research and development to find out the ever changing needs of the market and cater to the same, with the help of its carefully selected principals. The product portfolio offers a wide, unique & exclusive range of innovative, cost effective and eco-friendly products.

We are committed to provide the highest quality products and solutions therefore, we only supply globally recognized and approved products such as UL, FM, Kitemark, LPCB, CE, WRAS, Applus, AMCA and more. The product portfolio ranged from Shield's Steel & HDPE piping systems to the complete robust system for the industrial ventilation and more.

State-of-the-art FM approved HDPE Pipes are manufactured here in the UAE, with its full range. We do supply the fusion machines along with the technicians for on-site operations.

HDPE fittings category include segmented and moulded fittings with an option of custom fittings.

With representation in Middle East and North Africa (MENA) region, we simultaneously works on opportunities to explore new markets.

We believe in total customer satisfaction thus, ensure qualified and well-experienced support team to better understand your concerns and solve them in time.

---

# Fire & Smoke Dampers

---

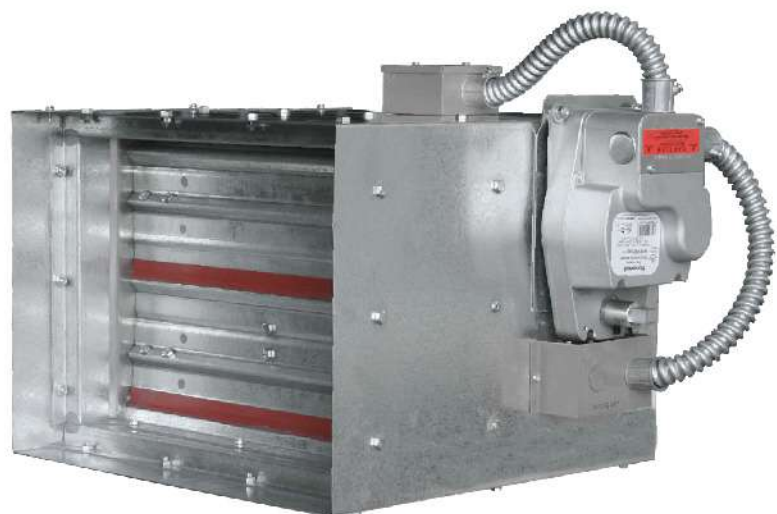

## Curtain Fire Damper NFC FD 4000 Series

### Models:

**NFC FD 4000 A: Blades inside air Stream**

**NFC FD 4000 B: Blades Partially inside air Stream**

**NFC FD 4000 C: Blades completely out of air Stream**

The design of modern era building construction projects involves highly complex and sophisticated infrastructure and requires total safety measures and energy efficient. One of the important measures in fire safety is to prevent human loss and project value. NAFFCO Fire Dampers are designed keeping in mind the safety of human life and property. Fire Dampers are required by International Uniform Building Code to maintain the Integrity and fire resistance rating of walls, partitions and floors.

**NFC FD 4000 SERIES**, Curtain type fire dampers are designed to block the spread of fire and smoke through ducts, walls, corridors or floors. These dampers are suitable for installation in walls & ceilings made from concrete, brickwork and gypsum having Fire resistance of 2 hours. Dampers are fitted with standard release 72 °C fusible links (UL listed).

**NFC FD 4000C CURTAIN FIRE DAMPERS** are made in accordance with BS 476 - parts 8 & 20, fire tested as per UL555 standard for safety. The fire endurance test requirements are based on recommendations as per NFPA 90A (Chapter 5.4.1.1 & 5.4.1). NAFFCO Fire Dampers are fire rated for 1.5 hrs and approved by local Civil Defence Authorities. These Fire Dampers with interlocking blades facilitates isolating compartments of fire in ventilation systems.



NFC FD 4000B



NFC FD 4000C



# Curtain Fire Damper NFC FD 4000 Series

## Models:

- NFC FD 4000 A: Blades inside air stream
- NFC FD 4000 B: Blades partially inside air stream
- NFC FD 4000 C: Blades completely out of air stream
- NFC FD 4000 C (M): Multi-section fire damper



Curtain Fire Damper  
with Installation Frame (HVAC)



## MODEL: NFC FD 4000C

(Blades completely out of air stream)

### STANDARD CONSTRUCTION

- **FRAME:** Frame is welded construction of GI sheet 1.2mm (18G) z-27
- **BLADE:** High quality roll formed GI blades 0.8mm thick ribbed for extra strength. Blades Interlocked
- **FUSIBLE LINK:** Standard Fusible Link fuses at 72°C (165°F) UL Listed
- **SPRINGS:** Constant Force Coil Springs of stainless steel
- **RAMP BRACKET:** Ramp Bracket to hold spring and for positive latching
- **FIRE RATING:** 1.5 hour firerated - V/H
- **FINISH:** Galvanized Mill Finish.

### OPTIONAL:

- **SLEEVE:** GI Steel as per NFPA Table 3.4.6.3
- **FUSIBLE LINK:** Other rating of 95°C (202°F), 124°C (260°F)
- **RETAINING ANGLE:** Minimum 40mm x 40mm x 1.6mm thick
- **INSTALLATION FRAME:** HVAC or as Required
- **MICRO SWITCH:** For BMS open-close indication
- **INDICATOR:** Externally mounted open, close visible
- **MATERIAL:** Can be stainless steel if specified.

### AVAILABLE OPTIONS

- NFC FD 4000 A - Blades inside air stream
- NFC FD 4000 B - Blades partially inside air stream
- NFC FD 4110 C (o/v) - Circular oval spigot
- NFC FD 4003 C - Firerated 3 hrs Dynamic V/H.
- NFC FD 4000 C - Multi-Section Fire Damper



NFC FD 4000C  
Blades completely  
out of air Stream



NFC FD 4110C (O)



Blades out  
of air Stream



Roll Form Frame



Multi-Section  
Fire Damper

**NOTE:** Standard construction is same as mentioned above.

## Motorized Combination Fire & Smoke Damper Model: NFC MFSD 4710

These Dampers are designed to block spread of fire & Smoke through ducts, walls and ceilings. Very efficient for use in Engineered Smoke Extraction System.



Motorized Combination  
Fire & Smoke Dampers  
(MFSD)

### SALIENT FEATURES

- Thermoelectric resetting device & spring return actuator
- Designed and Manufactured as per BS 476 – parts 8 & 20
- In accordance with UL555 & UL555S for Fire & Smoke Safety. Meets NFPA 90A
- Fire rating of 1.5/3 hrs with smoke leakage class I/II/III
- Isolates compartments of Fire in Ventilation Systems
- High performance Fire & Smoke isolating damper
- Can be used as Smoke Damper for Smoke Extraction System.

### MODEL: NFC MFSD 4710

#### STANDARD CONSTRUCTION

- **FRAME:** Frame material is GI steel sheet 16G, G 90
- **BLADES:** High quality, '3V' formed GI blades 1.5mm thick
- **JAMB SEALS:** Compression type. SS Side jamb seals for free movement of blades
- **LINKAGES:** Electroplated or GI steel. Opposed blade operation
- **BUSHES:** Brass/Bronze sintered bushes (Iolite)
- **JACK SHAFT:** 12.5mm or 1/2" diameter Zinc Electro-plated shaft
- **BLADE AXLES:** 12mm zinc electroplated or GI stub axles
- **BLADE STOP:** 18G (1.2mm) GI sheet formed angle
- **TIP SEALS:** Graphite/Silicon rubber blade tip seals standard
- **TRD:** Thermoelectric Tripping Device, 165°F (72°C) UL Listed
- **RATING:** Fire Rated for 1.5 or 3 hrs. & Smoke Leakage class I/II/III at 250°F or 350°F
- **ACTUATOR:** UL Listed spring return with 24V/230V AC Supply
- **SIZE:** Min. 6"x 8". Max. single section 36" X 36". Larger sizes in multi-section
- **UNDERSIZED:** Standard fabrication 1/4" undersized from the order size or specify exact size
- **SLEEVE:** Standard 270mm or 400mm, as required
- **VARIANTS:**
  - NFC MFSD 4710 - 3: Fire Rated 3hrs
  - NFC - MFSD 4710 S - Frame and blades in SS material
  - NFC - MFSD 4720 - Blade double wall 20G (1.0 mm) GI AEROFOIL..

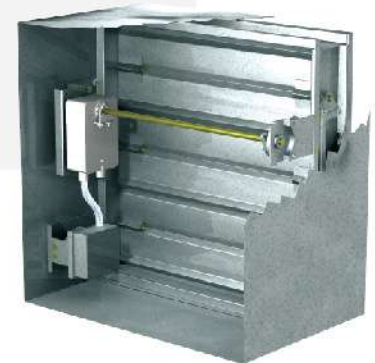

MFSD with actuator  
mounted inside



Multi frame MFSD



MOTORIZED Combination  
FIRE & SMOKE DAMPER

DIMENSIONS (mm)

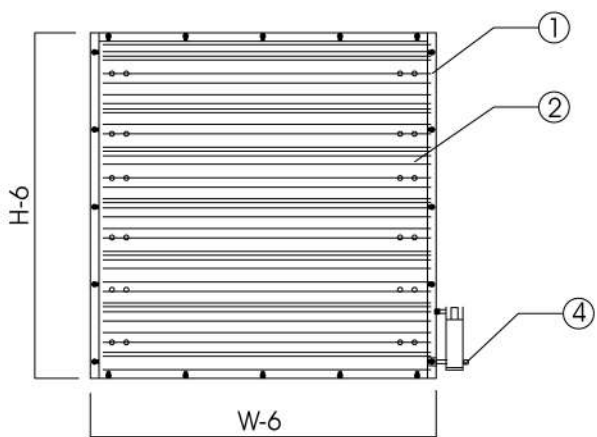
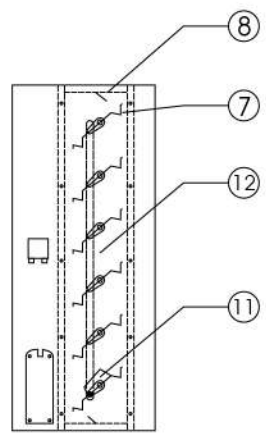
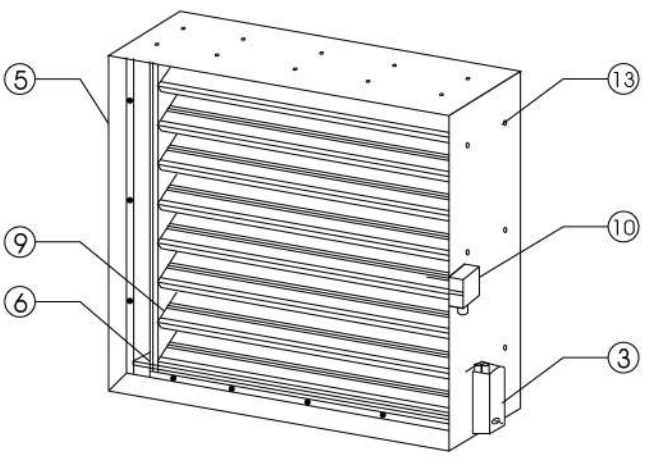
 <p style="text-align: center;">FRONT VIEW</p>	 <p style="text-align: center;">SECTIONAL VIEW</p>
 <p style="text-align: center;">ISOMETRIC VIEW</p>	<p><b>DESCRIPTION</b></p> <ol style="list-style-type: none"> <li>1. CASING G.I - 1.5MM</li> <li>2. 3V- GROOVE BLADES G.I - 1.5MM</li> <li>3. SPRING RETURN ACTUATOR</li> <li>4. JACK SHAFT</li> <li>5. SLEEVE</li> <li>6. BRASS BRUSH</li> <li>7. SILICON RUBBER TIP SEAL</li> <li>8. BLADE STOPPER</li> <li>9. SIDE SEAL</li> <li>10. THERMOELECTRIC RESETTABLE TRIPPING DEVICE</li> <li>11. JACK SHAFT LEVER</li> <li>12. SIDE LINKAGE</li> <li>13. BOLTS AND NUTS</li> </ol>



## Motorized Smoke Damper Model: NFC MSD 4610

The Motorized Smoke Dampers are designed to block spread of Smoke through ducts & also extraction of smoke through shafts.

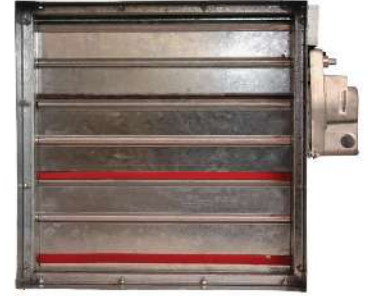

Motorized Smoke Damper

### SALIENT FEATURES

- Spring Return Actuator. Can take signal from FACP through smoke detector
- Designed and Manufactured as per BS 476 - parts 8 & 20
- In accordance with UL555S standard for Fire Safety. Meets NFPA 90A
- Smoke leakage class I/II/III
- Isolates compartments of Smoke in Ventilation systems
- Suitable for installation in sheet metal ductwork.

### MODEL: NFC MSD 4610 STANDARD CONSTRUCTION

- **FRAME:** Frame material is GI steel sheet 16G, G-90
- **BLADES:** High quality, '3V' formed GI blades 1.5mm thick
- **JAMB SEALS:** Compression type SS. Side jamb seals for free movement of blades
- **LINKAGES:** Electroplated or GI steel. Opposed blade operation
- **BUSHES:** Brass / Bronze sintered bushes (iolite)
- **JACK SHAFT:** 12.5mm or 1/2" diameter Zinc Electro-plated shaft
- **BLADE AXLES:** 12mm zinc electroplated or GI studs
- **BLADE STOP:** 18G (1.2mm) galvanized steel sheet angle
- **ACTUATOR:** UL Listed spring return with 24V/230V AC Supply
- **RATING:** UL listed with smoke leakage class I at 250°F or 350°F
- **SIZE:** Min. 150mm x 150mm max. single section 914mm x 914mm. Larger sizes in multi-section
- **UNDERSIZED:** 1/4" under ordered size unless specified exact size
- **SLEEVE:** Standard 200mm, 250mm or big size as required
- **VARIANTS:** NFC MSD 4610 S - Frame & blade in SS material  
NFC MSD 4620 - Class II @ 250°F or 350°F.

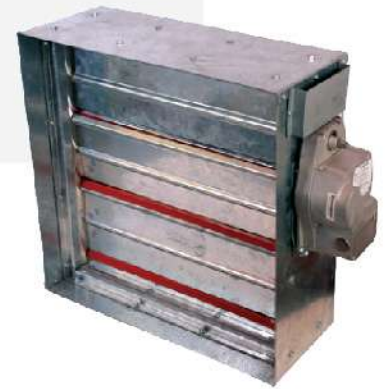

Motorized Smoke Damper

MOTORIZED SMOKE DAMPER

DIMENSIONS (mm)

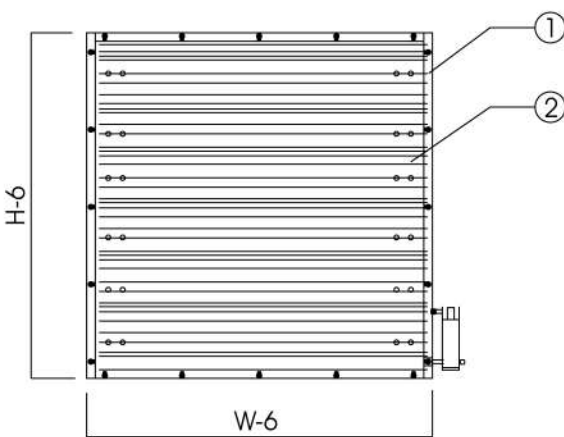
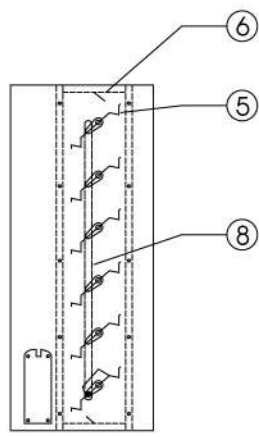
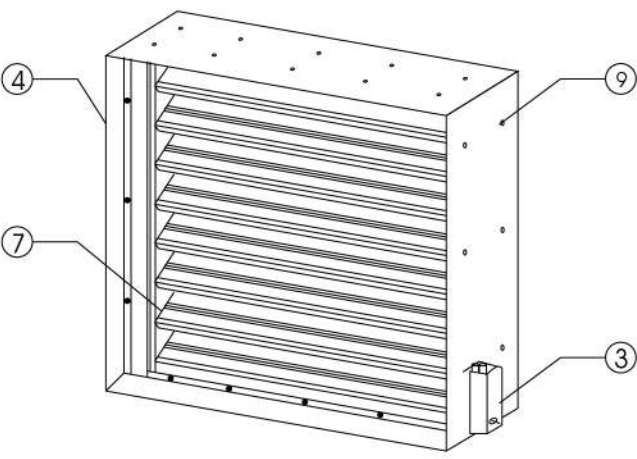
 <p style="text-align: center;">FRONT VIEW</p>	 <p style="text-align: center;">SECTIONAL VIEW</p>
 <p style="text-align: center;">ISOMETRIC VIEW</p>	<p><b>DESCRIPTION</b></p> <ol style="list-style-type: none"> <li>1. CASING G.I - 1.5MM</li> <li>2. 3V- GROOVE BLADES G.I - 1.5MM</li> <li>3. SPRING RETURN ACTUATOR</li> <li>4. SLEEVE - 200 mm</li> <li>5. SILICON RUBBER TIP SEAL</li> <li>6. BLADE STOPPER</li> <li>7. SIDE SEAL</li> <li>8. SIDE LINKAGE</li> <li>9. BOLTS AND NUTS</li> </ol>





Fusible Link & Spring  
Return Actuator

## Motorized Fire Damper Model: NFC MFD 4810

The Motorized Fire dampers are designed to control spread of fire through ducts, walls, floors and ceilings.

### SALIENT FEATURES

- Fusible link or Thermoelectric tripping device (TRD) with spring return actuator
- Designed and Manufactured as per BS 476 - parts 8 & 20
- In accordance with UL555 standard for Fire Safety. Meets NFPA 90A
- Fire rating of 1.5/3 hrs; Static and Dynamic
- Isolates compartments of Fire in Ventilation system
- Block the spread of fire through ducts, partition walls or floors.

### MODEL: NFC FD 4810

### STANDARD CONSTRUCTION

- **FRAME:** Frame material is GI steel sheet 16G, G-90
- **BLADES:** High quality, '3V' formed GI blades 1.5mm thick
- **JAMB SEALS:** Compression type. SS Side jamb seals for free movement of blades
- **LINKAGES:** Electroplated or GI steel. Opposed blade operation
- **BUSHES:** Brass/Bronze sintered bushes (iolite)
- **JACK SHAFT:** 12.5mm or 1/2" diameter Zinc Electro-plated shaft
- **BLADE AXLES:** 12mm zinc electroplated or GI studs
- **BLADE STOP:** 18G (1.2mm) galvanized steel formed angle
- **FUSIBLE LINK:** Standard fusible link 165°F (72°C) UL Listed or Thermoelectric Tripping Device (TRD)
- **ACTUATOR:** UL Listed spring return with 24V/230V actuator
- **SIZE:** Min. 150mm x 150mm. Larger sizes in multi-section 36" X 36" single section
- **UNDERSIZED:** 1/4" under ordered size unless specified exact
- **VARIANTS:** NFC MFD 4810 S - Frame & blade in SS material  
NFC MFD 4820 - Blade double wall 20G (1 mm) GI AEROFOIL.



MFD without sleeves



TRD & Spring Return Actuator

## Access Door Model: NFC AD 4025

Access doors are designed to provide access to Fire dampers, Volume control dampers and Filters etc. in Ventilation system.



### ACCESS DOOR

Duct Access door allows easy and convenient access while providing a secure, positive seal when closed. The NFC AD 4000 series models offer quality, access doors with double skin construction in accordance with SMACNA requirements and quick simple installation. Access doors provide easy mounting and positive closure. All models are available in a wide variety of sizes to suit any specific application.

#### MODEL: NFC AD 4025 STANDARD CONSTRUCTION

Double walled 24 Gauge (0.7mm), Galvanized steel sheet door panel for strength Frame construction in 22 Gauge (0.9mm)

- 1" (25mm) thick Fibre glass wool insulation for reduced noise and heat transfer
- Notched knock-over tabs.
- Progressive action, zinc plated cam-locks for positive closure
- Synthetic gasket for positive seal.

#### AVAILABLE OPTIONS

- 1-1/2" (40mm) thick fibreglass wool insulation
- Or 2" (50mm) thick fibreglass wool insulation.

#### MODEL: NFC AD 4025 H

- Continuous hinge on one edge
- One Cam-lock on opposite edge (centrally) sizes up to 350mm
- Two Cam-locks on opposite edge on larger sizes.

#### MODEL: NFC AD 4025 RH

- Butt hinged on one edge
- One Cam-lock on opposite edge centrally placed for sizes up to 350mm
- Two Cam-locks on opposite edge on larger sizes.



Access door with handles & cam lock



Access door with continuous hinges & cam lock

ACCESS DOOR

DIMENSIONS (mm)

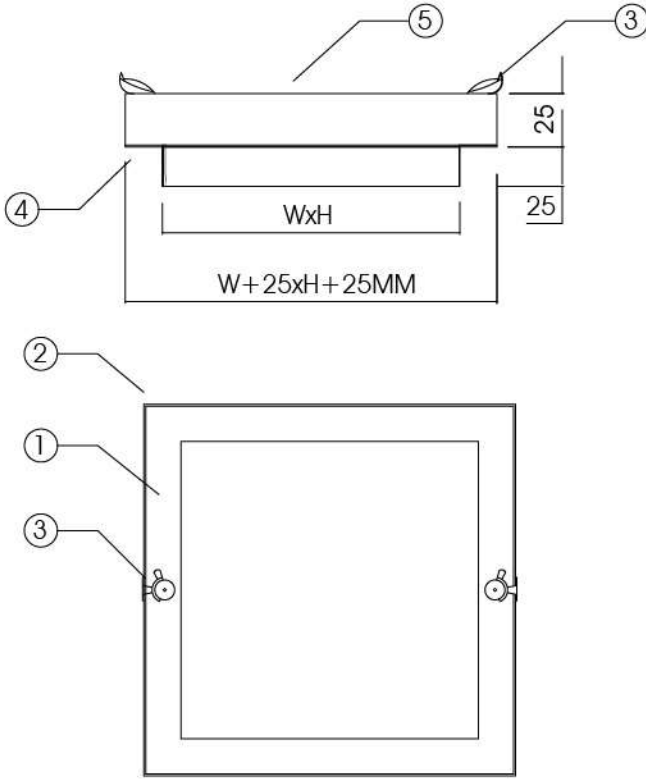
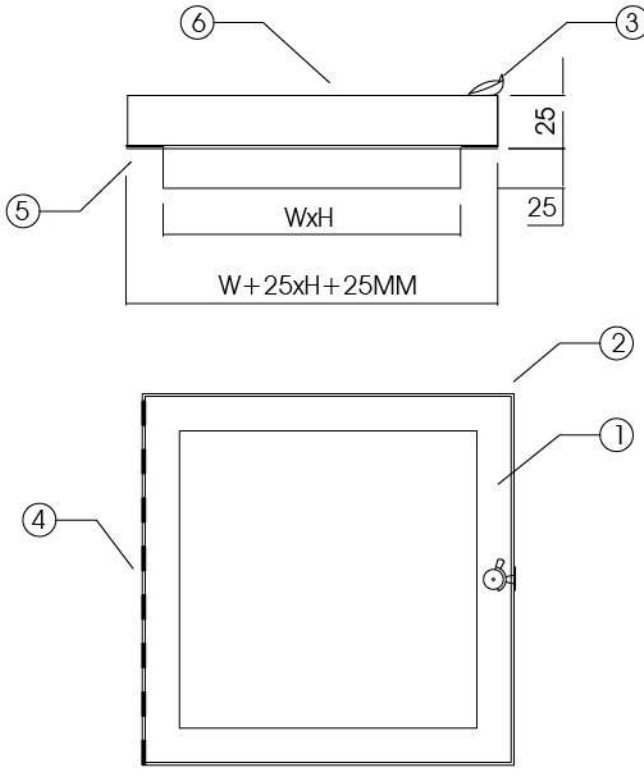
	
<p><b>ACCESS DOOR - NFC AD 4025</b></p> <p><b>DESCRIPTION</b></p> <ol style="list-style-type: none"> <li>1. DOOR PANEL</li> <li>2. FRAME</li> <li>3. SELF TIGHTENING CAM LOCKS</li> <li>4. 12MM WIDE GASKET</li> <li>5. MINERAL WOOL INSULATION</li> </ol>	<p><b>ACCESS DOOR - NFC AD 4025H</b></p> <p><b>DESCRIPTION</b></p> <ol style="list-style-type: none"> <li>1. DOOR PANEL</li> <li>2. FRAME</li> <li>3. SELF TIGHTENING CAM LOCKS</li> <li>4. CONTINUOUS HINGED</li> <li>5. 12MM WIDE GASKET</li> <li>6. MINERAL WOOL INSULATION</li> </ol>

**AVAILABLE SIZES (MM)**

W x H	HOLE SIZES*
200 x 150	200 x 150
200 x 200	200 x 200
300 x 300	300 x 300
600 x 600	600 x 600

\*NOTE: Holes in ductwork must be cut in accordance with sizes above.

In line with NAFFCO Flow Control policy for continuous product development, NAFFCO Flow Control has the right to change specifications without prior notice.

---

# Volume Control Dampers

---





NFC VD 2100 G-G-F  
VCD with '3V' GI Single Skin Blades

## Volume Control Damper NFC VD 2000 SERIES

### USAGE & APPLICATION

NAFFCO high quality Volume Control Dampers are designed for quiet, efficient and reliable air volume control in HVAC systems. These dampers allow even distribution and control of airflow under conditions of high duct pressures.



NFC VD 2200 G-AL-F  
VCD with AL 'Aerofoil' Blades

### MODELS

- **NFC VD 2100 G-G-F** (Flange type, Single Skin Blade)
- **NFC VD 2200 G-G-F** (Flange type, Double Skin Blade).

### STANDARD CONSTRUCTION

- **FRAME:** 1.2mm thick (18G) GI. Integral Flange for duct connections
- **BLADE:** 1.2mm thick (18G) GI, single skin blades '3V' form. or 1.5mm GI double skin 'aerofoil' shape. Dampers up to 250mm height are single blade construction
- **BEARINGS:** Nylon/PVC bush is standard. Brass/Sintered Bronze oil impregnated bush optional
- **AXLES:** Square or Round. Spindles are either welded/riveted or bolted as per specification
- **LINKAGE:** 3x12mm zinc plated flat steel linkage. Opposed blades. Linkage external & concealed
- **QUADRANT:** GI manual lockable quadrant with "open", "1/2", "1/4" & "close" markings
- **TIP SEAL:** Rubber foam gasket at the blade tips to min. air leakage in "close" position
- **SIZE:** Single section min. size 150x150mm & max. 1200x1200mm
- **FINISH:** Mill finish
- **OPTIONAL:** Position indicators for 'open/close' indication are optional.



NFC MVD 2200 G-AL-F  
Multi-section Motorized VCD

### AVAILABLE OPTIONS

- **NFC VD 2200 G-AL-F:** same as above but blades are Extruded Double skin AL
- **NFC VD 2100 G-S-F:** same as above but blades are SS
- **NFC VD 2100 S-S-F:** same as above but Frame, blades, spindles are SS
- **NFC MVD 2100 G-G-F:** same as above with BELIMO/HONEYWELL actuator.
- **NFC FRVD 2200 G-G-F:** Fire Rated VCD



# Volume Control Damper NFC VD 2000 SERIES

## MODELS

- **NFC VD 2100 G-G-SL** (Sleeve type, Single Skin Blade)
- **NFC VD 2200 G-G-SL** (Sleeve type, Double Skin Blade).

Motorized VCD  
with Actuator



## STANDARD CONSTRUCTION

- **FRAME:** 1.2mm thick (18G) GI. 'HAT' shape for duct connections
- **BLADE:** 1.2mm thick (18G) GI, single skin blades '3V' form. or 1.5mm GI double skin 'aerofoil' shape
- **BEARINGS:** Nylon/PVC bush is standard. Brass/Sintered Bronze oil impregnated bush optional
- **AXLES:** Square or Round. Spindles are either welded/riveted or bolted as per specification
- **LINKAGE:** 3x12mm zinc plated flat steel linkage. Opposed blades opn. Linkage external concealed
- **QUADRANT:** GI manual lockable quadrant with "open", "1/2", "1/4" & "close" markings
- **TIP SEAL:** Rubber foam gasket at the blade tips to minimize air leakage in "close" position
- **SIZE:** Single section min. size 150x150mm & max. 1200x1200mm. Larger sizes as multiple sections
- **SLEEVE:** Suitable gauge of all around sleeve provided for motorized operation
- **FINISH:** Mill finish
- **OPTIONAL:** Position indicators for 'open/close' indication are optional.



NFC VD 2100 G-G-SL  
Opposed blade operation

## AVAILABLE OPTIONS

- **NFC VD 2200 G-AL-SL:** same as above but blades are Extruded Double skin AL
- **NFC VD 2100 G-S-SL:** same as above but blades are SS
- **NFC VD 2100 S-S-SL:** same as above but Frame, blades, spindles are SS
- **NFC MVD 2100 G-G-SL:** same as above with BELIMO/HONEYWELL actuator.



VCD with Sleeve  
Type Frame

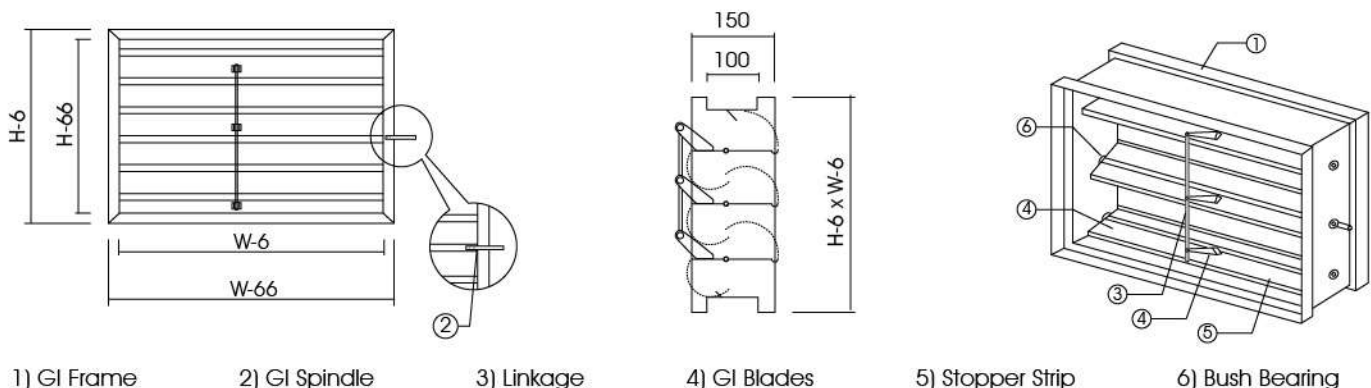



NFC VD 2200 G-G-P

## Volume Control Damper NFC VD 2000 SERIES

Volume Control Dampers are designed for quiet, efficient and reliable air volume control in ventilation system.

### MODELS

- NFC VD 2200 G-G-P
- NFC VD 2200 G-G-S&C.

NFC VD 2200  
G-AL-S&C



### STANDARD CONSTRUCTION

- **FRAME:** 1.2mm thick (18G) GI. Frame shape is plain 'box' type or "Slip & Clip" joint to suit ductwork connections. Frame is a spot welded construction
- **BLADE:** 1.2mm thick GI, single skin blades '3V' formed or 1.5mm double skin 'aerofoil' shape. Damper up to 250mm height is single blade construction
- **BEARINGS:** Nylon/PVC bush is standard. Brass/Sintered Bronze bush optional
- **AXLES:** Square/Round. Spindles are either weld/riveted/bolted as per specs.
- **LINKAGE:** 3x12mm zinc plated flat steel linkage. Opposed blades open. Linkage external concealed
- **QUADRANT:** Manual lockable with "open", '1/2', '1/4' & "close" markings
- **TIP SEAL:** Rubber foam gasket at the blade tips to minimize air leakage in "close" position
- **SIZE:** Single section min. size 150x150mm & max. 600x600mm
- **FINISH:** Mill finish.

### AVAILABLE OPTIONS

- OVCD-220 G-AL-SP: same as above but Blades are AL aerofoil shape
- OVCD-220 G-AL-SC: same as above but Blades are AL aerofoil shape.



Multi-Frame VCD

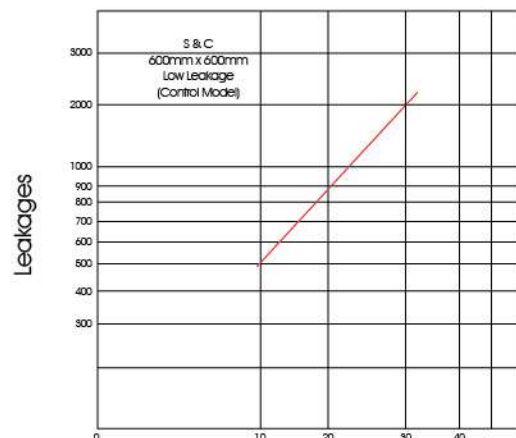
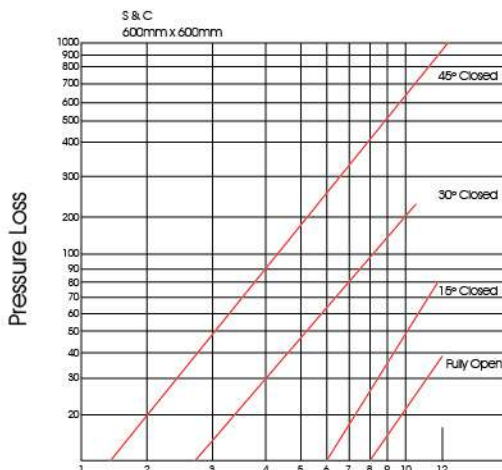

## ROUND VCD NFC RVD 2100 SERIES

Volume Control Dampers are designed for quiet, efficient and reliable air volume control in ventilation system with Round Ducts.



NFC RVD 2100 G-G-R

### USAGE & APPLICATION

- NFC RVD 2100 Circular Damper allows even distribution and control of airflow under conditions of high duct pressures. Dampers can be manual with a manual locking quadrant or motorized with a wide range of electrical actuators.

### MODELS

- NFC RVD 2100 G-G-R.



Motorized Round VCD  
NFC MRVD 2100 G-G-R

### STANDARD CONSTRUCTION

- **CASING:** GI casing 24G/22G for dia. up to 350mm & 22G/20G for higher dia. Round casing is manufactured by rolling suitable size GI sheet and spot welded at seam edges. Swagging at both ends to accommodate ductwork connections
- **BLADE:** GI steel single skin blades, 1.8mm thick for sizes up to 500mm. 1.6mm for sizes above 500mm diameter. Single skin blades are cut to round shape, reinforced at centre to accommodate spindle assembly and provide toughness
- **BEARINGS:** Brass/Nylon/PVC bush standard. Bronze bush optional
- **AXLES:** Blades are weld/riveted with Zinc plated axles. Square or round
- **QUADRANT:** GI manual lockable with "open", "1/2", "1/4" & "close" markings
- **TIP SEAL:** Rubber foam gasket at the blade round edge to minimize air leakage in "close" position
- **FINISH:** Mill finish
- **SIZE:** Min. 100mm, Max. 600mm diameter. Dampers up to 600mm are single blade construction
- **OPTIONAL:** Position indicators for 'open/close' indication are optional.

### AVAILABLE OPTIONS

- NFC MRVD 2100 G-G-R

STANDARD CONSTRUCTION

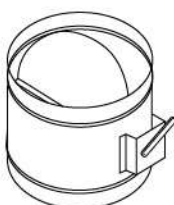

1) Frame

MOUNTING BRACKET

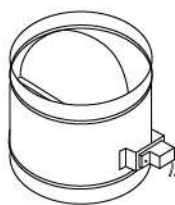

2) Blade

3) Spindle

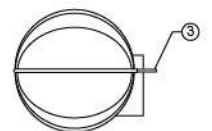
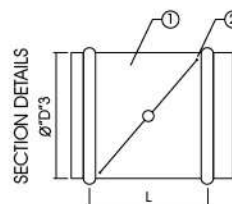



Pressure Relief Damper

**Non Return Damper  
Model: NFC NRD-2000**

**Pressure Relief Damper  
Model: NFC PRD-2000**

## USAGE & APPLICATION

- NAFFCO make Non Return Dampers (NFC NRD 2000 series) are designed for automatic shut off of individual sections of the air conditioning system. With the fan in running condition, the degree of blade opening is a function of air velocity. If the fan is turned off, the blade will close automatically. In a multi fan installation this prevents back draughts through non-operating fan
- NAFFCO make Pressure Relief Dampers, NFC PRD 2000 series models are also called Self Closing Dampers or Gravity Dampers or Pressure Relief Dampers. The blades are smooth, reliable and designed for energy saving. These are air operated, opening or closing dampers for intake, discharge and pressure relief vents in air conditioning systems. Also, designed to maintain a constant air pressure level inside pressurized rooms.

## MODELS

- **NFC NRD 2000 IW / NFC PRD 2000 IW:** Internal wall mounted
- **NFC NRC 2000 RD / NFC PRD 2000 RD:** Round duct mounted
- **NFC NRD 2000 SD / NFC PRD 2000 SD:** Rectangular duct mounted
- **NFC NRD 2000 EW / NFC PRD 2000 EW:** External wall mounted.

## STANDARD CONSTRUCTION

- **CASING:** The casing is made from high quality AL/GI sheet steel of 1.8G thickness
- **BLADES:** Blades are made of 0.6mm to 1.0mm thickness AL/GI steel sheet. Parallel action blades
- **BUSHES:** Blades are fitted with nylon bushes for rattle free and smooth operation
- **GASKETS:** Blades are sealed with foam/rubber gasket at the bottom edge to prevent rattling noise and facilitate air tight operation
- **OPERATION:** Frame is fitted with AL/GI stopper to prevent the over movement of blades. Additional centre partition shall be provided if height or length is more than 900mm.



Non-Return Damper  
Wall Mounted



Non-Return Damper  
Wall Mounted

**Non Return Damper  
Model: NFC NRD-2000**

**Pressure Relief Damper  
Model: NFC PRD-2000**



Pressure Relief Damper  
Wall Mounted

DIMENSIONS (MM)

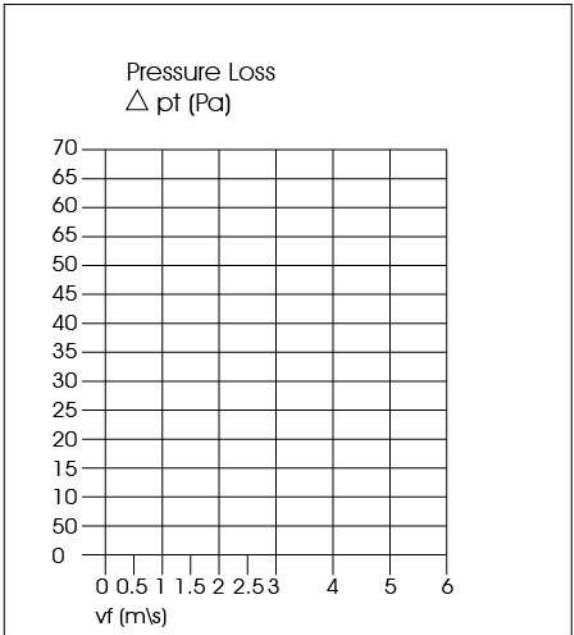
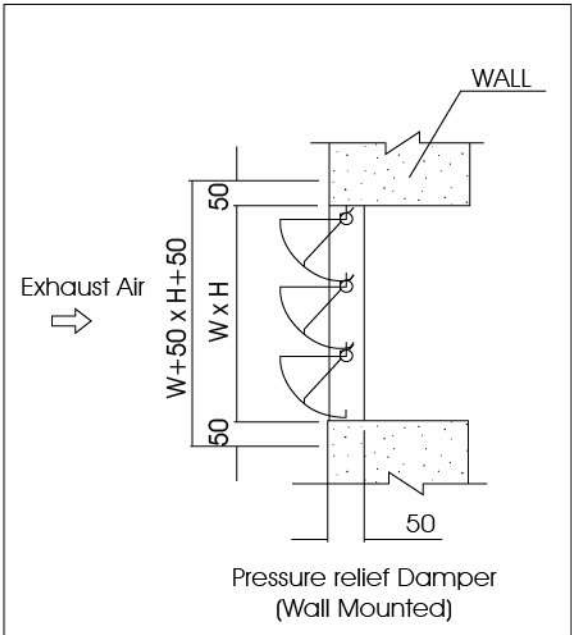
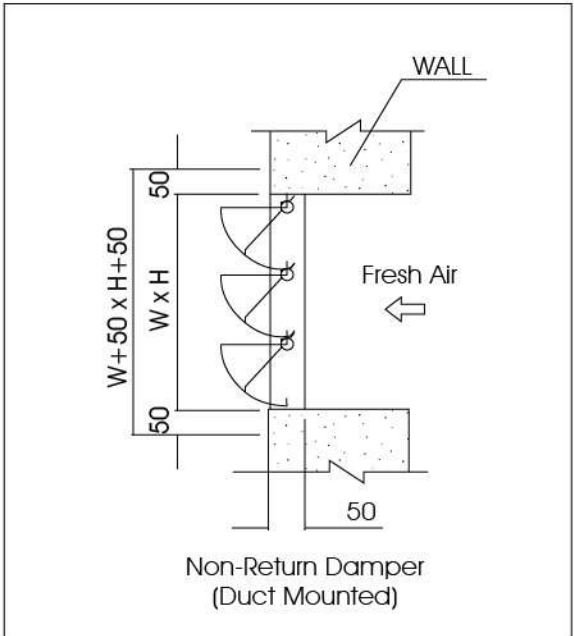
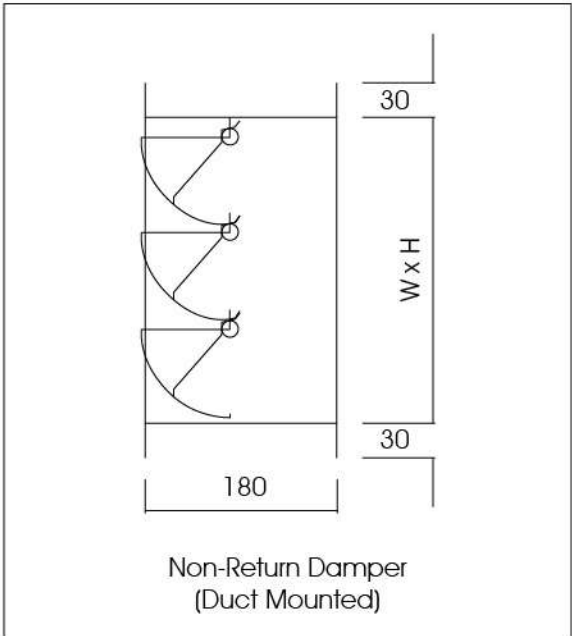

---

# Fresh Air & Sand Trap L O U V E R S

---

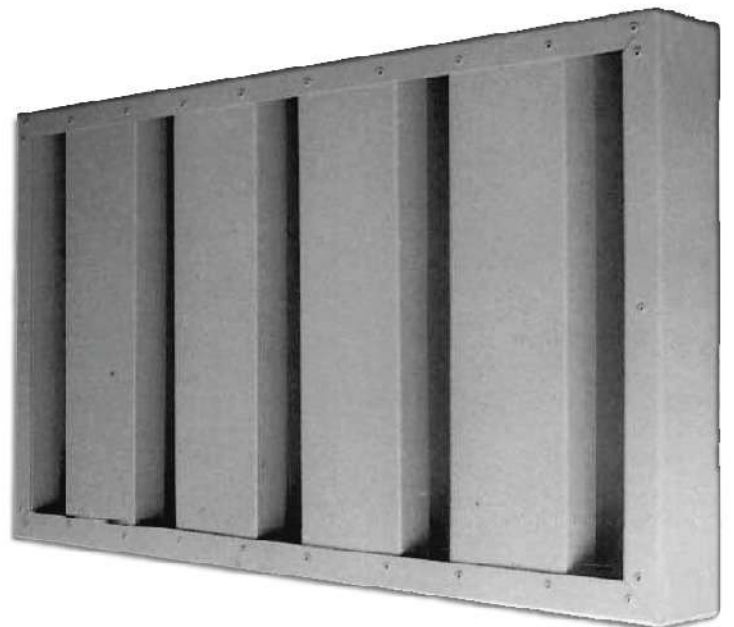
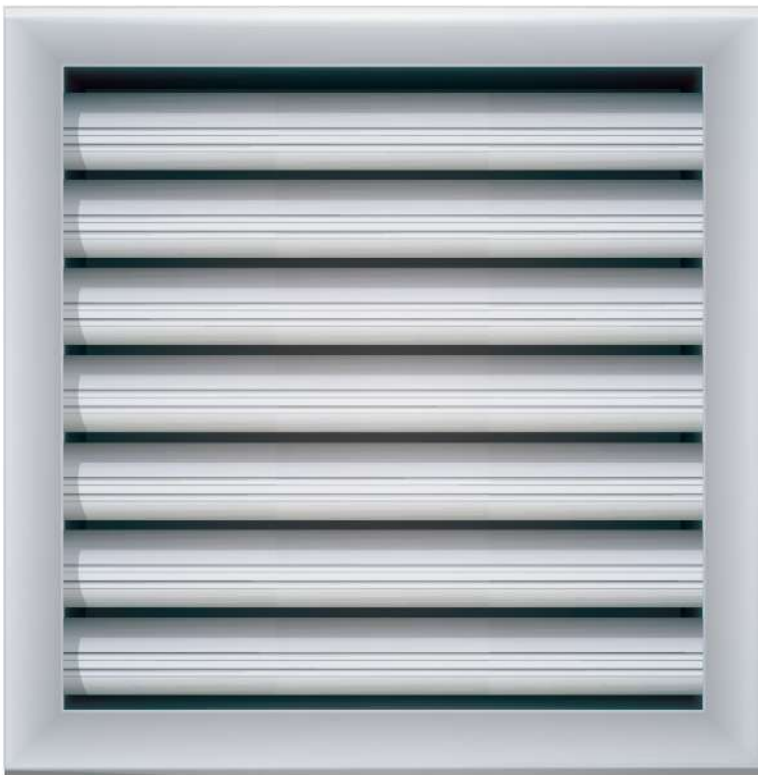

## Sand Trap Louver

Sand Trap Louver act as a pre-filter for air conditioning plants to protect from extreme levels of environment pollution & sand dust.

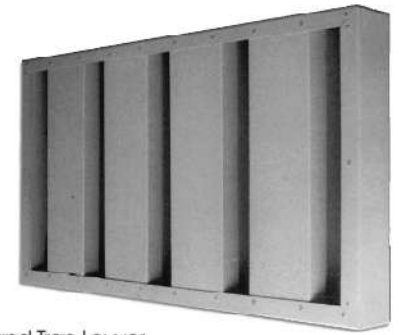

Sand Trap Louver

### USAGE & APPLICATION

- The sand trap louver is used at the fresh air inlet side. It lowers the dust loading of conventional filtration as it is designed to separate large size sand particles at low to medium speeds
- The STL is designed to separate large particles at low air velocities, thus avoiding excessive dust loading of conventional filters. It's not intended as a substitute for conventional supply air filtration plant
- The vertically arranged sections and holes at the bottom surface to drain separated sand particles ensure that STL is self-cleaning and maintenance-free.



STL with Mesh

### FEATURES

1. Designed for intake applications to separate sand from Inlet air
2. For bigger sizes, several split sections can be combined to provide any size
3. Multi-sections are supplied with additional sand chute & loose channels for fitting on site
4. Provided with auto emptying sand drain holes from the base
5. Choice of either galvanized steel or aluminium construction
6. Range of Bird mesh and Insect Screens, as an option to protect against unwanted objects.



STL with sand chute



Sand Trap Louver

## Model: NFC STL GI 9710 Standard Construction

### STANDARD CONSTRUCTION

- **FRAME:** 1.2mm thick GI sheets G-90, as per ASTM653 Standard
- **BLADES:** 0.9mm to 1.2mm thick GI sheets G-90, as per ASTM653 Standard
- **ASSEMBLY:** Mechanically fastened with GI rivets
- **BIRD MESH:** 1/2" x 1/2" x 0.051" or 12mm x 12mm x 1mm dia. wire GI mesh PVC coated
- **FINISH:** Mill Finish.

### OPTIONS (UPGRADES)

- Powder Coated or Spray Paint Finish
- Variety of Bird and Insect Mesh
- Heavy duty STL with frame of 14G GI
- Fresh Air Intake System with Wire Mesh, VCD, sliding AL Filter (removable).

### DIMENSIONS

- Width 'W' and Height 'H' are opening dimensions
- STL is provided with approximately 1/2" undercut
- Shipping weight is approximately 4 lbs/sq.ft
- Sizes: Standard sizes are as below. Other sizes are optional
  - Min. size panel = 12" W x 10" H
  - Max. single Panel = 64" W x 48" H.



### NFC STL GI 9710 DIMENSION (STANDARD)

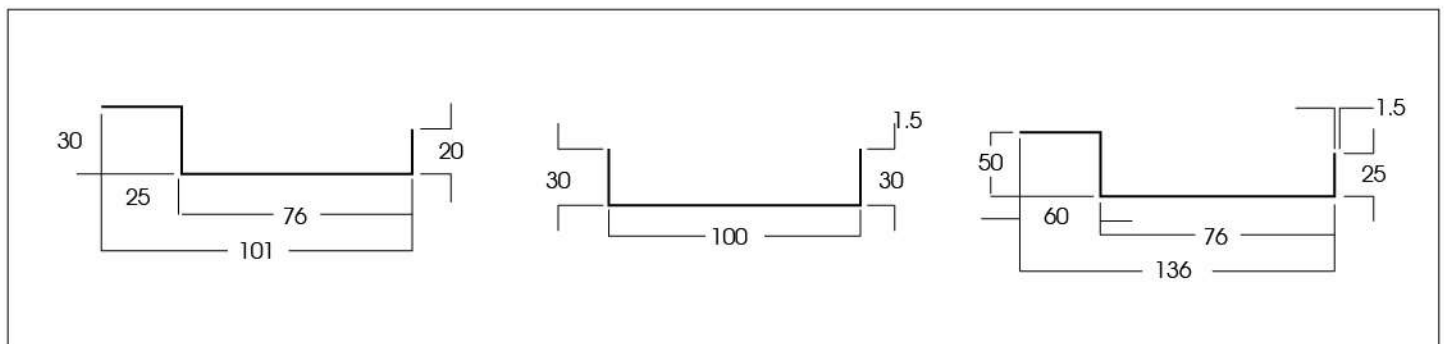



# Sand Trap Louver

Sand Trap Louver act as a pre-filter for air conditioning plants to protect from extreme levels of environment pollution.



Sand Trap Louver

ASSEMBLY SKETCHES

VERTICAL SECTION

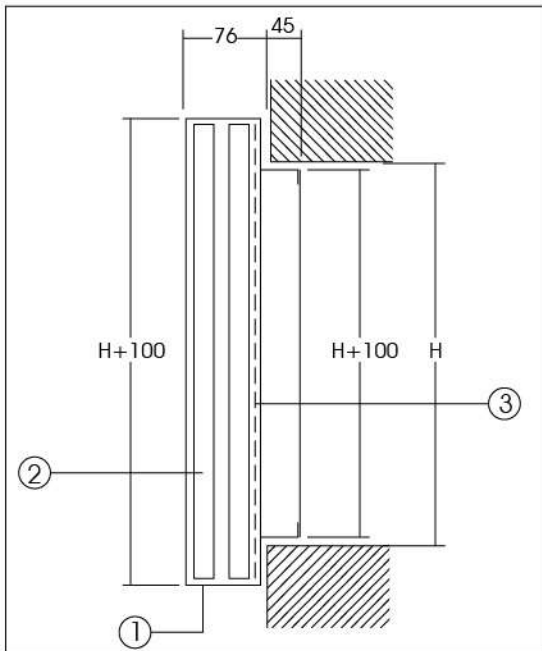

HORIZONTAL SECTION

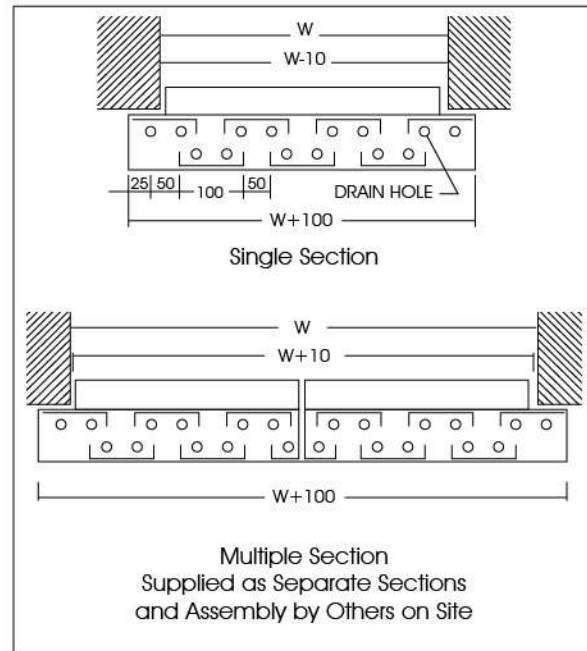

SINGLE SECTION WITH SAND CHUTE

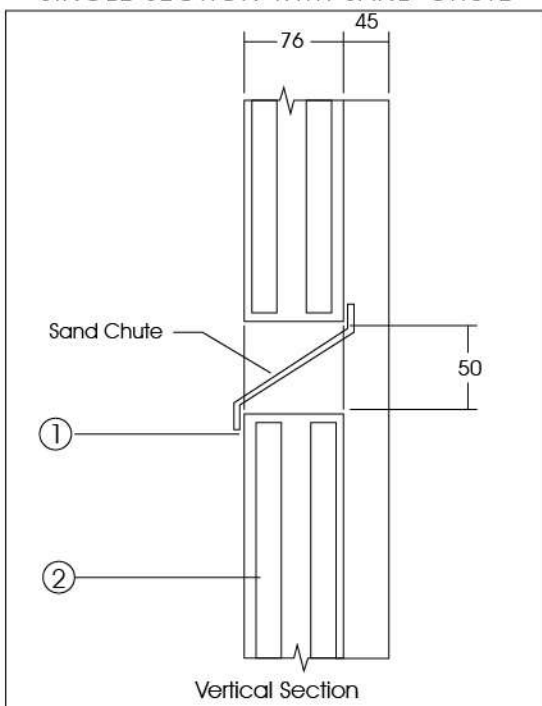

MULTIPLE SECTION WITH SAND CHUTE

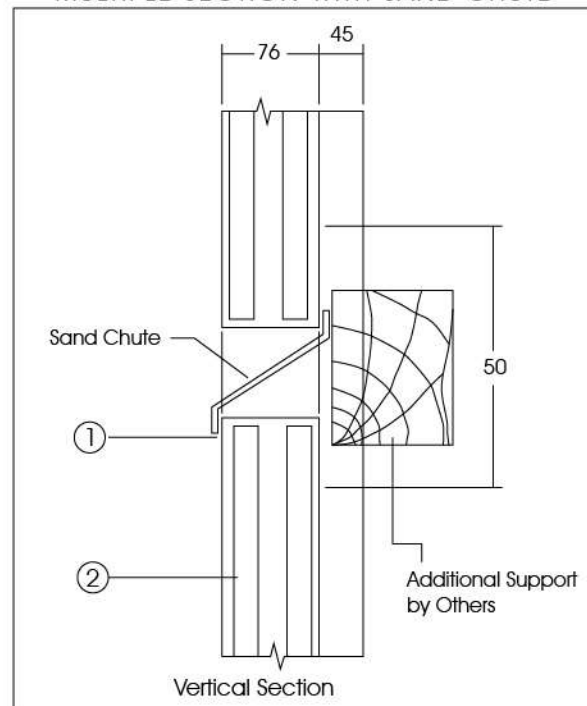



Sand Trap Louver - Aluminium

**Sand Trap Louver**  
**Model: NFC STL AL 9710**

Sand Trap Louver act as a pre-filter for air conditioning plants to protect from extreme levels of industrial pollution.

## MODEL: NFC STL AL 9710

### STANDARD CONSTRUCTION

- **FRAME:** 1.1mm thick nominal; 6063-T6 extruded aluminium alloy. Conform to BS1474
- **BLADES:** 1mm thick nominal; 6063-T6 extruded aluminium alloy. Conform to BS1474
- **ASSEMBLY:** Mechanically fastened with AL Rivets 4.8mm x 12mm
- **SCREEN:** 1/2" x 1/2" x 0.051" diameter wire or 12mm x 12mm x 1mm AL coated wire
- **FINISH:** Mill Finish or Powder coated.

### OPTIONS (UPGRADES)

- Powder Coated or Spray paint Finish
- Variety of Bird and Insect Mesh
- Heavy duty STL with frame of 2 to 2.5mm thickness
- Fresh Air Intake System with Wire Mesh, VCD, sliding AL Filter (removable).

### DIMENSIONS

- Width 'W' and Height 'H' are opening dimensions
- STL is provided with approximately 1/2" undercut
- Shipping weight is approximately 3 lbs/sq.ft
- Standard sizes are as below. Other sizes are optional
  - Min. size panel = 12" W x 10" H
  - Max. single panel = 64" W x 48" H.



## Sand Removal Efficiency

ASSEMBLY SKETCHES

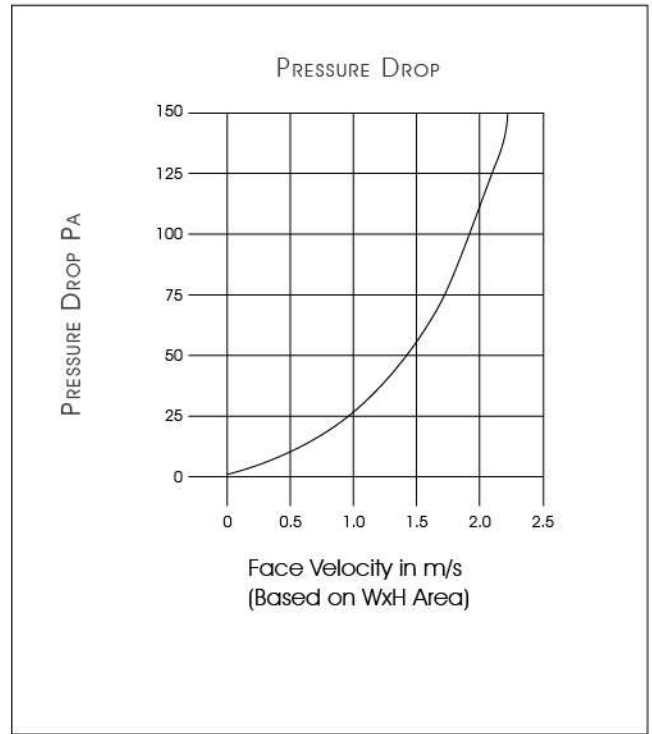
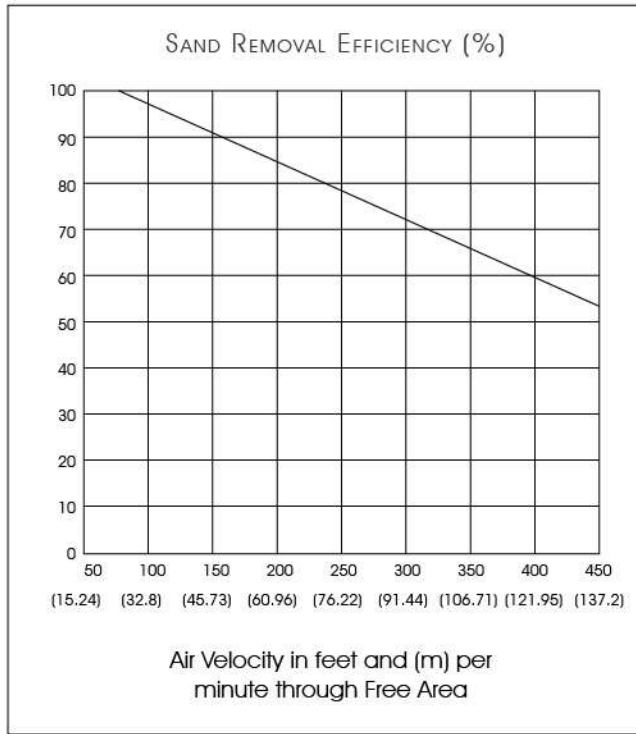

Performance Data		
The Filtration Performance is Dependant on the Dust Type & The Velocity of The Air		
Particle Size	Filtration Efficiency in %	
Range	@ 1.0m/s	@ 2.0m/s
350 - 700	90	70
75 - 700	60	Approx. 30

## NFC STL AL 9710 Extruded Sections

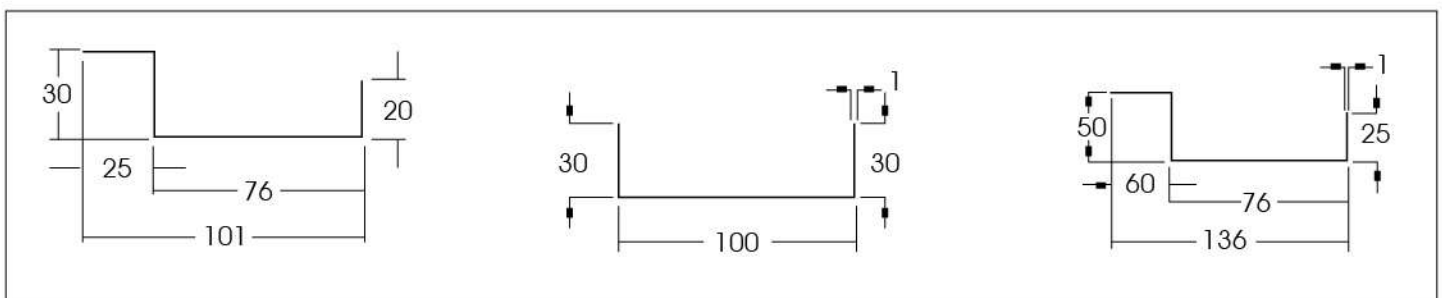

**NOTE:** Dimensional Tolerance as per EN: 12020-2-2001, EN 755-9-2001



## Fresh Air Louver Model: NFC FAL GI 9910

Stationary Louver is designed to provide air intake and air exhaust openings in building exterior walls to protect against the direct ingress of rain.

### MODEL: NFC FAL GI 9910 STANDARD CONSTRUCTION

The blades are positioned on 45mm to 93mm minimum centres up to 112mm maximum centres at 45 degrees and has a high free area to provide minimum resistance to airflow.

- **FRAME:** Gauge 16 ga. /18 ga. from formed Galvanized steel sheet
- **BLADES:** Gauge 18 ga. / 20 ga. from formed Galvanized steel sheet
- **BIRD SCREEN:** Galvanized steel, 12 x 12 x 1mm (std. supply)
- **MIN SIZE:** 300mm x 300mm
- **MAX SIZE:** 1200mm W x 2000mm H as single section. (Up to 2200mm W x 2000mm H as a single section with vertical mullion on centre. Larger sizes will be in multiple sections).

### OPTIONS:

- Code Z - Painted to RAL (Epoxy coated)
- Code I - Insect Screen in galvanized steel 1mm x 1mm x 0.4mm
- Code T - Bird Screen in Stainless steel 12mm x 12mm x 0.7mm.

Louver wall with door  
for enclosure

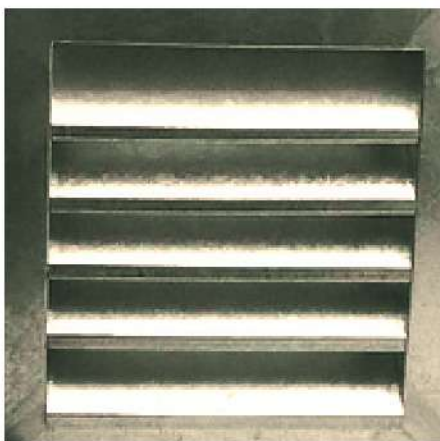

Fresh Air Louver - GI



**MODEL: NFC FAL GI 9910**  
**ASSEMBLY DETAILS – MULTIPLE SECTIONS**

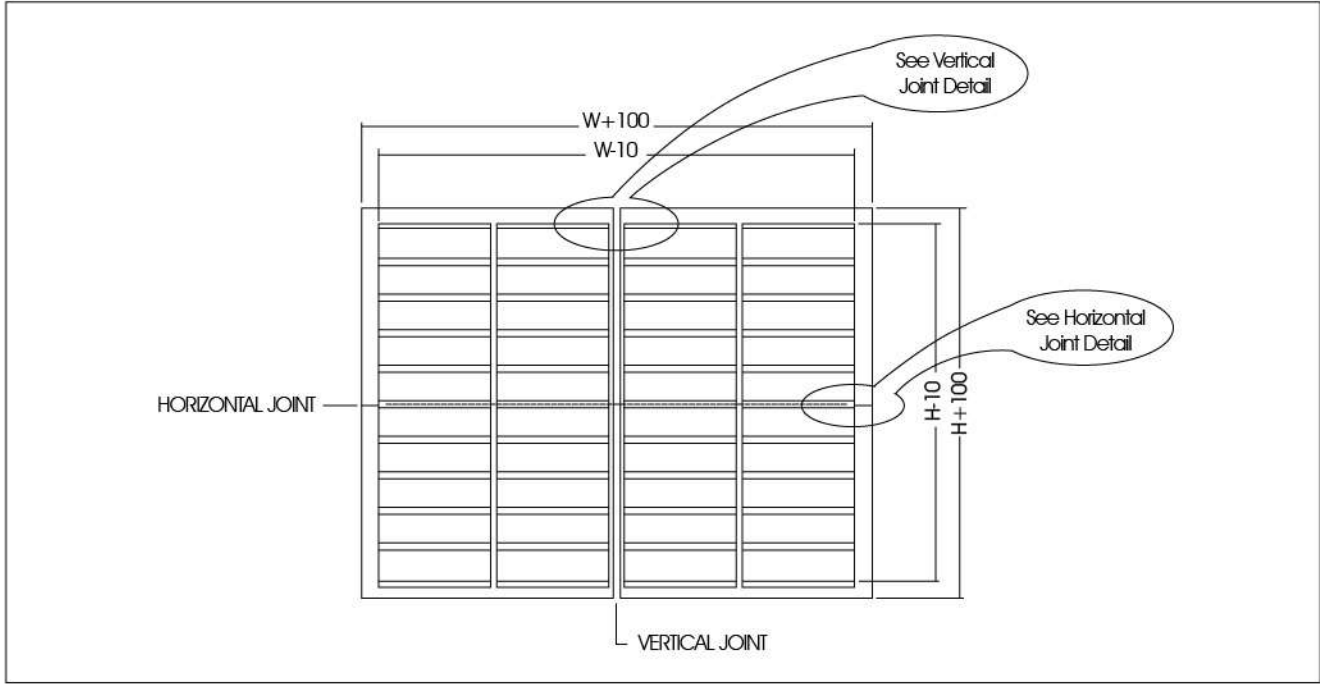

Vertical Joint Detail

Horizontal Joint Detail

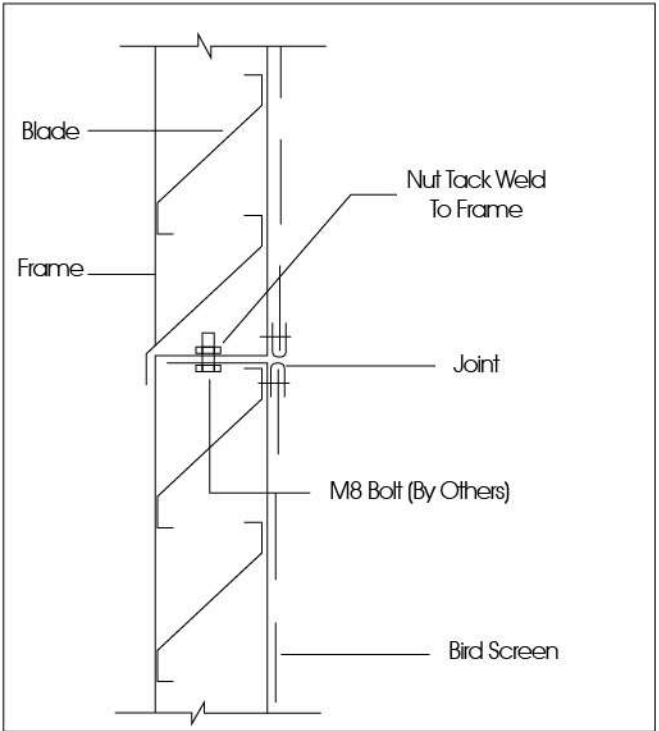
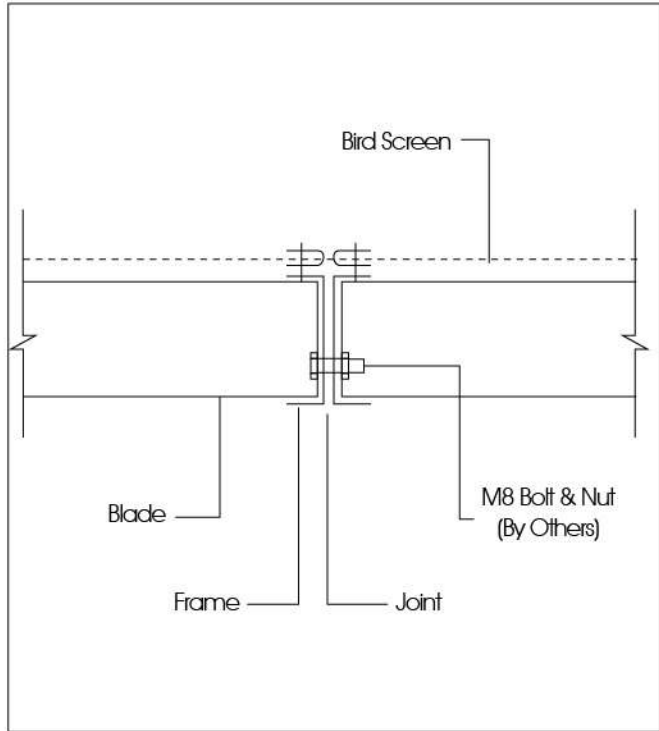



## Fresh Air Louver

Stationary Louver is designed to provide air intake and air exhaust openings in building exterior walls to protect against the direct ingress of rain.

### MODEL: NFC FAL AL 9910

#### STANDARD CONSTRUCTION

The blades are positioned on 45mm to 104mm minimum centres up to 118mm maximum centres at 45 degrees and has a high free area to provide minimum resistance to airflow.

- **FRAME:** Extruded aluminium profile 1.5mm thick
- **BLADES:** Extruded aluminium profile 1.2mm thick
- **STANDARD FINISH:** Mill aluminium finish
- **SCREEN:** Expanded aluminium bird screen
- **MIN SIZE:** 300mm x 300mm
- **MAX SIZE:** 1200mm W x 2000mm H - Larger sizes will be in multiple sections.

#### OPTIONS (UPGRADES)

- Code A - Anodized aluminium in silver
- Code P - Polyester powder coated
- Code Z - Painted to RAL (epoxy coated)
- Code I - Expanded aluminium insect screen
- Code T - Bird screen in stainless steel 12mm x 12mm x 0.7mm.

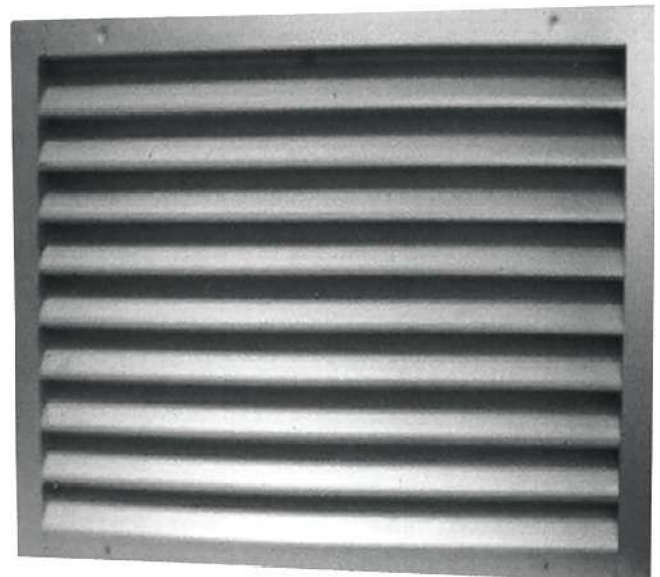

NFC FAL AL 9910

# MODEL: NFC FAL AL 9910

## ASSEMBLY – SINGLE SECTION

1. Casing      2. Blade      3. Bird Screen

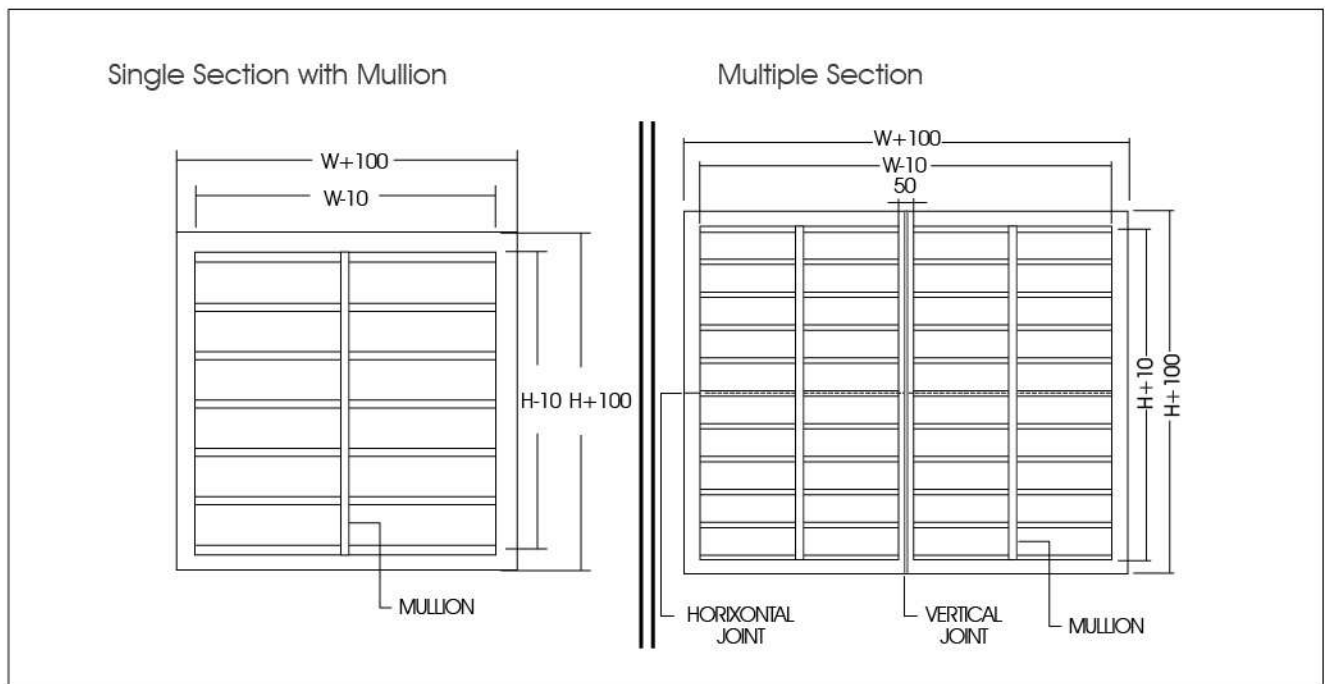
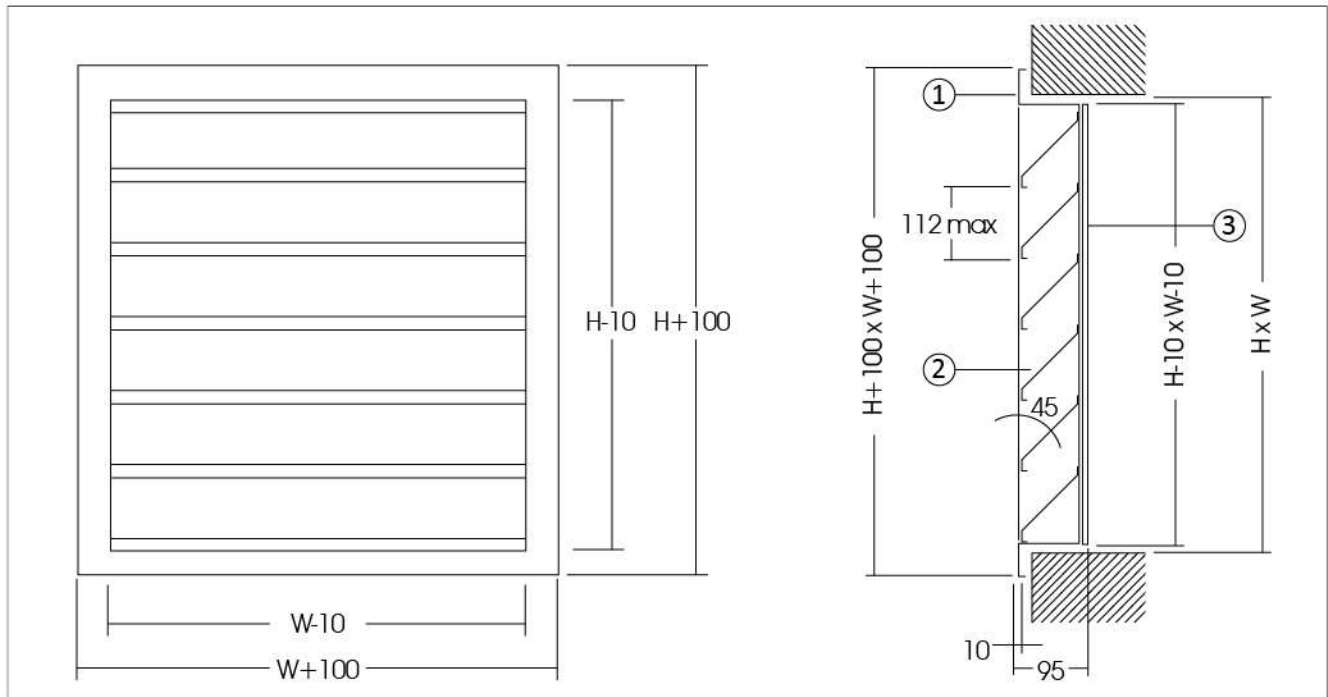

## Technical Data

### Model: NFC FAL AL 9910

Application of stationary louver selecting velocity through free area that gives an acceptable pressure drop for intake and exhaust application.

### SELECTION PROCEDURE FOR STATIONARY LOUVERS

Select Fresh Air Intake Louver with a given Air volume of 1 Cu. m/s and 3.5 m/s free area velocity.

Determine Louver Free Area:

- A. Dividing the given air volume (1.5 Cu.m/s) by free area velocity (3.5 m/s, do not exceed to 4.2 m/s for fresh air intake application).
- B. Select a suitable louver from Free Area Chart
  - 1.0m Wide x 1.3m High,
  - 1.2m Wide x 1.1m High,
  - 1.4m Wide x 1.0m High.
- C. Check the pressure drop of the selected louver on the Pressure Drop Chart:  
The pressure drop across the selected size of louvers is 25 Pa.





# Technical Data

## Model: NFC FAL AL 9910

Application of stationary louver selecting velocity through free area that gives an acceptable pressure drop for intake and exhaust application.

### LOUVER FREE AREA CHART

H (m)	Width (m)																			
	0.3	0.4	0.5	0.6	0.7	0.8	0.9	1	1.1	1.2	1.3	1.4	1.5	1.6	1.7	1.8	1.9	2	2.1	2.2
0.3	0.013	0.018	0.024	0.029	0.035	0.040	0.045	0.051	0.057	0.062	0.064	0.070	0.075	0.081	0.087	0.092	0.098	0.103	0.109	0.114
0.4	0.022	0.032	0.042	0.052	0.062	0.072	0.082	0.091	0.101	0.111	0.115	0.124	0.134	0.144	0.154	0.164	0.174	0.184	0.193	0.203
0.5	0.030	0.044	0.057	0.071	0.084	0.098	0.111	0.125	0.138	0.152	0.156	0.170	0.183	0.196	0.210	0.223	0.237	0.250	0.264	0.277
0.6	0.039	0.056	0.073	0.090	0.107	0.124	0.141	0.158	0.175	0.192	0.198	0.215	0.232	0.249	0.266	0.283	0.300	0.317	0.334	0.352
0.7	0.047	0.067	0.088	0.109	0.129	0.150	0.171	0.191	0.212	0.233	0.240	0.260	0.281	0.302	0.322	0.343	0.364	0.384	0.405	0.426
0.8	0.055	0.079	0.103	0.128	0.152	0.176	0.201	0.225	0.249	0.273	0.282	0.306	0.330	0.355	0.379	0.403	0.427	0.452	0.476	0.500
0.9	0.063	0.910	0.119	0.147	0.175	0.203	0.230	0.258	0.286	0.314	0.324	0.352	0.379	0.407	0.435	0.463	0.491	0.519	0.547	0.575
1	0.082	0.119	0.155	0.191	0.228	0.264	0.300	0.337	0.373	0.409	0.422	0.458	0.495	0.531	0.567	0.604	0.640	0.676	0.713	0.749
1.1	0.091	0.132	0.172	0.213	0.253	0.293	0.334	0.374	0.415	0.455	0.469	0.509	0.549	0.590	0.630	0.671	0.711	0.751	0.792	0.832
1.2	0.099	0.143	0.187	0.231	0.275	0.319	0.363	0.407	0.451	0.495	0.510	0.554	0.598	0.642	0.686	0.730	0.774	0.818	0.862	0.906
1.3	0.107	0.155	0.203	0.250	0.298	0.345	0.393	0.440	0.488	0.536	0.552	0.599	0.647	0.694	0.742	0.789	0.837	0.885	0.932	0.980
1.4	0.116	0.167	0.218	0.269	0.320	0.371	0.422	0.474	0.525	0.576	0.593	0.644	0.695	0.747	0.798	0.849	0.900	0.951	1.002	1.053
1.5	0.124	0.178	0.233	0.288	0.343	0.397	0.452	0.507	0.562	0.616	0.635	0.690	0.744	0.799	0.854	0.909	0.963	1.018	1.073	1.127
1.6	0.132	0.190	0.248	0.307	0.365	0.423	0.482	0.540	0.598	0.657	0.677	0.735	0.793	0.852	0.910	0.968	1.027	1.085	1.143	1.202
1.7	0.140	0.202	0.264	0.326	0.388	0.450	0.512	0.574	0.635	0.697	0.718	0.780	0.842	0.904	0.966	1.028	1.090	1.152	1.214	1.276
1.8	0.148	0.214	0.279	0.345	0.410	0.476	0.541	0.607	0.672	0.738	0.760	0.826	0.891	0.957	1.022	1.088	1.153	1.219	1.284	1.350
1.9	0.156	0.225	0.295	0.364	0.433	0.502	0.571	0.640	0.709	0.778	0.802	0.871	0.940	1.009	1.079	1.148	1.217	1.286	1.355	1.424
2.0	0.164	0.237	0.310	0.383	0.455	0.528	0.601	0.674	0.746	0.819	0.844	0.917	0.989	1.062	1.135	1.208	1.280	1.353	1.426	1.499

In line with NAFFCO Flow Control policy for continuous product development, NAFFCO Flow Control has the right to change specifications without prior notice.



## Extract Air Louver

Stationary Louver is designed to provide air intake and air exhaust openings in building exterior walls to protect against the direct ingress of rain.

### MODEL: NFC EAL AL 9910

#### STANDARD CONSTRUCTION

The blades are positioned on 45mm to 104mm minimum centres up to 118mm maximum centres at 45 degrees and has a high free area to provide minimum resistance to airflow.

- **FRAME:** Extruded aluminium profile 1.5mm thick
- **BLADES:** Extruded aluminium profile 1.2mm thick
- **STANDARD FINISH:** Powder coated to RAL 9010/9016 Colour
- **SCREEN:** Bird screen/Wire mesh in GI/AL
- **MIN SIZE:** 150mm x 1500mm
- **MAX SIZE:** 3000mm W x 30000mm H - in single section, larger sizes will be in multiple sections.

#### OPTIONS (UPGRADES)

- Other colours are available upon request.
- Bird screen/Wire mesh in stainless steel 12mm x 12 mm x 0.7mm

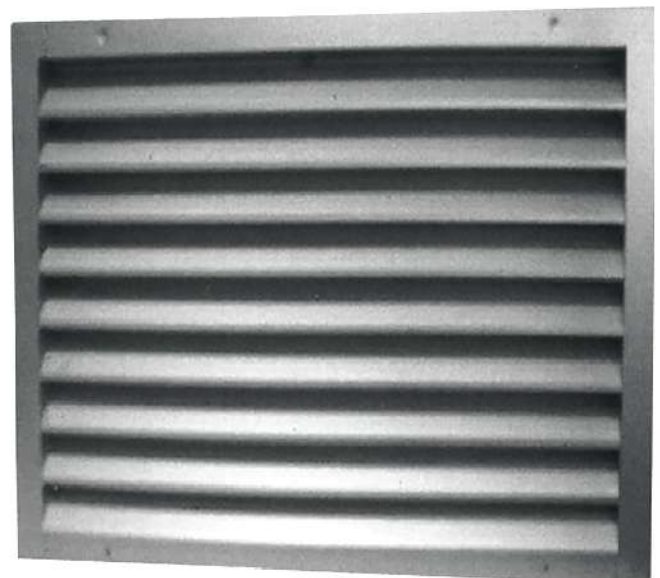

NFC FALAL 9910

# MODEL: NFC EAL AL 9910

## ASSEMBLY – SINGLE SECTION

1. Casing      2. Blade      3. Bird Screen

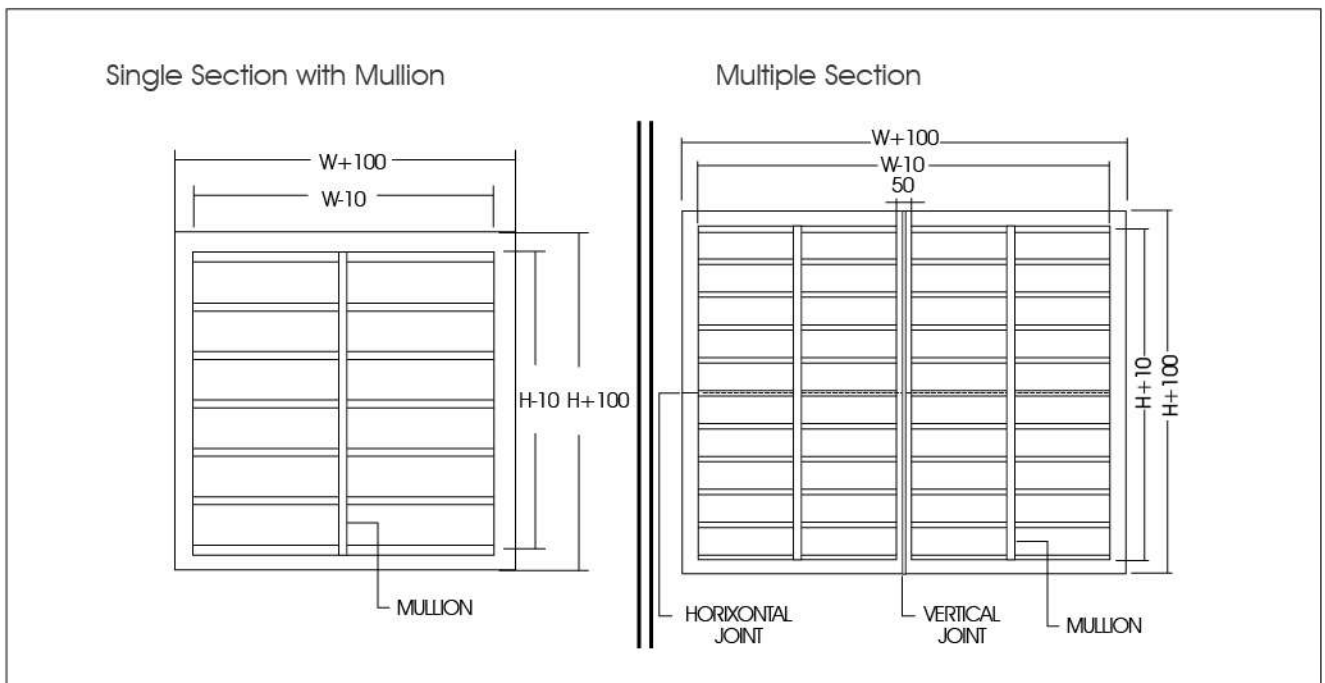
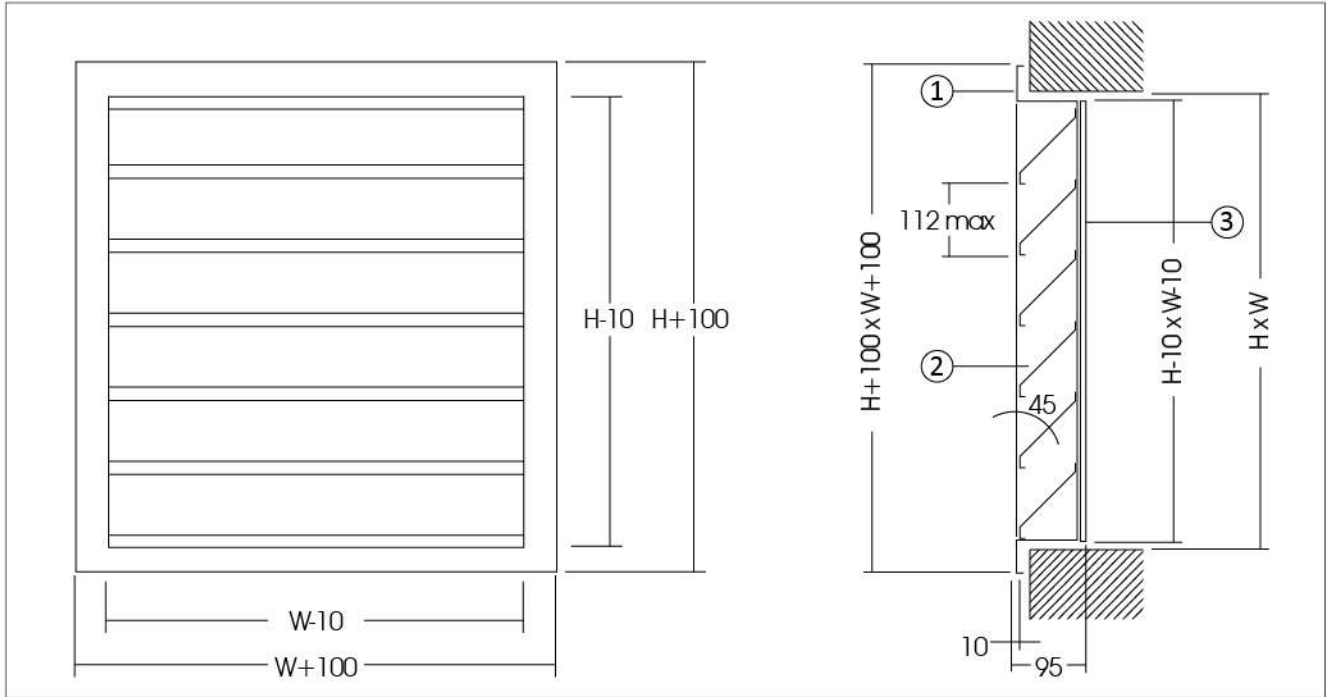

## Technical Data

### Model: NFC EAL AL 9910

Application of stationary louver selecting velocity through free area that gives an acceptable pressure drop for intake and exhaust application.

## SELECTION PROCEDURE FOR STATIONARY LOUVERS

Select Extract Air Louver with a given Air volume of 1 Cu. m/s and 3.5 m/s free area velocity.

Determine Louver Free Area:

- A. Dividing the given air volume (1.5 Cu.m/s) by free area velocity (3.5 m/s, do not exceed to 4.2 m/s for air application).
- B. Select a suitable louver from Free Area Chart
  - 1.0m Wide x 1.3m High,
  - 1.2m Wide x 1.1m High,
  - 1.4m Wide x 1.0m High.
- C. Check the pressure drop of the selected louver on the Pressure Drop Chart:  
The pressure drop across the selected size of louvers is 25 Pa.



# Technical Data

## Model: NFC EAL AL 9910

Application of stationary louver selecting velocity through free area that gives an acceptable pressure drop for intake and exhaust application.

### LOUVER FREE AREA CHART

H (m)	Width (m)																			
	0.3	0.4	0.5	0.6	0.7	0.8	0.9	1	1.1	1.2	1.3	1.4	1.5	1.6	1.7	1.8	1.9	2	2.1	2.2
0.3	0.013	0.018	0.024	0.029	0.035	0.040	0.045	0.051	0.057	0.062	0.064	0.070	0.075	0.081	0.087	0.092	0.098	0.103	0.109	0.114
0.4	0.022	0.032	0.042	0.052	0.062	0.072	0.082	0.091	0.101	0.111	0.115	0.124	0.134	0.144	0.154	0.164	0.174	0.184	0.193	0.203
0.5	0.030	0.044	0.057	0.071	0.084	0.098	0.111	0.125	0.138	0.152	0.156	0.170	0.183	0.196	0.210	0.223	0.237	0.250	0.264	0.277
0.6	0.039	0.056	0.073	0.090	0.107	0.124	0.141	0.158	0.175	0.192	0.198	0.215	0.232	0.249	0.266	0.283	0.300	0.317	0.334	0.352
0.7	0.047	0.067	0.088	0.109	0.129	0.150	0.171	0.191	0.212	0.233	0.240	0.260	0.281	0.302	0.322	0.343	0.364	0.384	0.405	0.426
0.8	0.055	0.079	0.103	0.128	0.152	0.176	0.201	0.225	0.249	0.273	0.282	0.306	0.330	0.355	0.379	0.403	0.427	0.452	0.476	0.500
0.9	0.063	0.910	0.119	0.147	0.175	0.203	0.230	0.258	0.286	0.314	0.324	0.352	0.379	0.407	0.435	0.463	0.491	0.519	0.547	0.575
1	0.082	0.119	0.155	0.191	0.228	0.264	0.300	0.337	0.373	0.409	0.422	0.458	0.495	0.531	0.567	0.604	0.640	0.676	0.713	0.749
1.1	0.091	0.132	0.172	0.213	0.253	0.293	0.334	0.374	0.415	0.455	0.469	0.509	0.549	0.590	0.630	0.671	0.711	0.751	0.792	0.832
1.2	0.099	0.143	0.187	0.231	0.275	0.319	0.363	0.407	0.451	0.495	0.510	0.554	0.598	0.642	0.686	0.730	0.774	0.818	0.862	0.906
1.3	0.107	0.155	0.203	0.250	0.298	0.345	0.393	0.440	0.488	0.536	0.552	0.599	0.647	0.694	0.742	0.789	0.837	0.885	0.932	0.980
1.4	0.116	0.167	0.218	0.269	0.320	0.371	0.422	0.474	0.525	0.576	0.593	0.644	0.695	0.747	0.798	0.849	0.900	0.951	1.002	1.053
1.5	0.124	0.178	0.233	0.288	0.343	0.397	0.452	0.507	0.562	0.616	0.635	0.690	0.744	0.799	0.854	0.909	0.963	1.018	1.073	1.127
1.6	0.132	0.190	0.248	0.307	0.365	0.423	0.482	0.540	0.598	0.657	0.677	0.735	0.793	0.852	0.910	0.968	1.027	1.085	1.143	1.202
1.7	0.140	0.202	0.264	0.326	0.388	0.450	0.512	0.574	0.635	0.697	0.718	0.780	0.842	0.904	0.966	1.028	1.090	1.152	1.214	1.276
1.8	0.148	0.214	0.279	0.345	0.410	0.476	0.541	0.607	0.672	0.738	0.760	0.826	0.891	0.957	1.022	1.088	1.153	1.219	1.284	1.350
1.9	0.156	0.225	0.295	0.364	0.433	0.502	0.571	0.640	0.709	0.778	0.802	0.871	0.940	1.009	1.079	1.148	1.217	1.286	1.355	1.424
2.0	0.164	0.237	0.310	0.383	0.455	0.528	0.601	0.674	0.746	0.819	0.844	0.917	0.989	1.062	1.135	1.208	1.280	1.353	1.426	1.499

In line with NAFFCO Flow Control policy for continuous product development, NAFFCO Flow Control has the right to change specifications without prior notice.

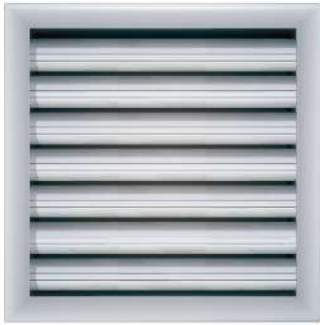

## Fresh Air Louver

Stationary Louver is designed to provide air intake and air exhaust openings in building exterior walls to protect against the direct ingress of rain.

### MODEL: NFC FAL AL 9510

General construction as type NFC FAL AL 9510 but with drainable frame and blades. Drain gutter in each blade and downspouts in vertical frames allows water to drain from louver to minimize water cascade from blade to blade.

### SINGLE SECTION

1. Casing      2. Blade      3. Bird Screen

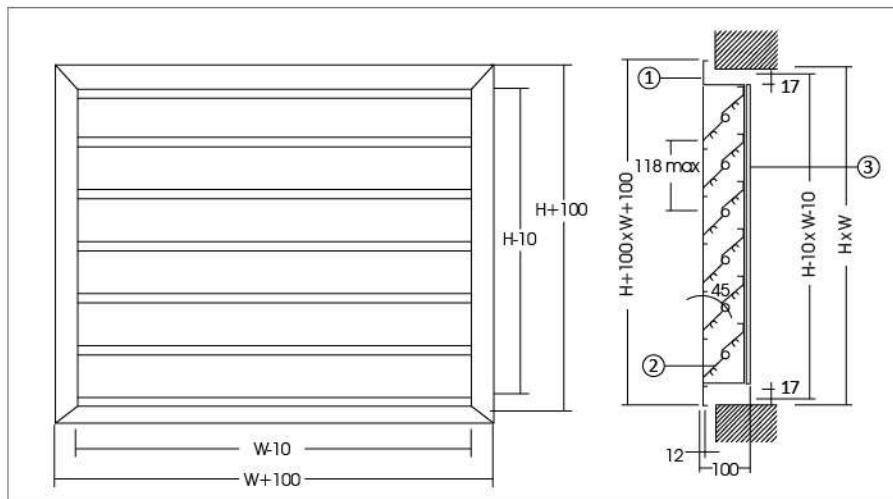

### SINGLE SECTION

1. Drainable Frame      2. Drainable Blades      3. Bird Screen

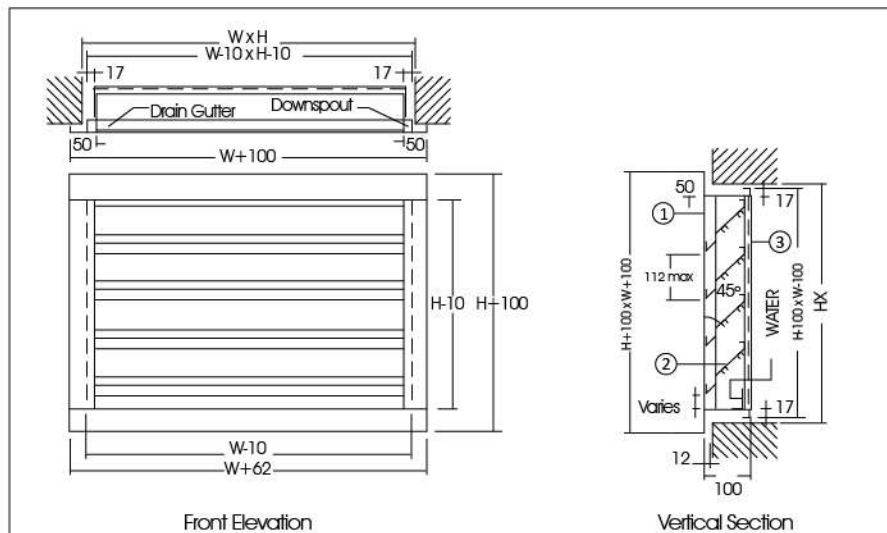





**NAFFCO**  
FLOW CONTROL

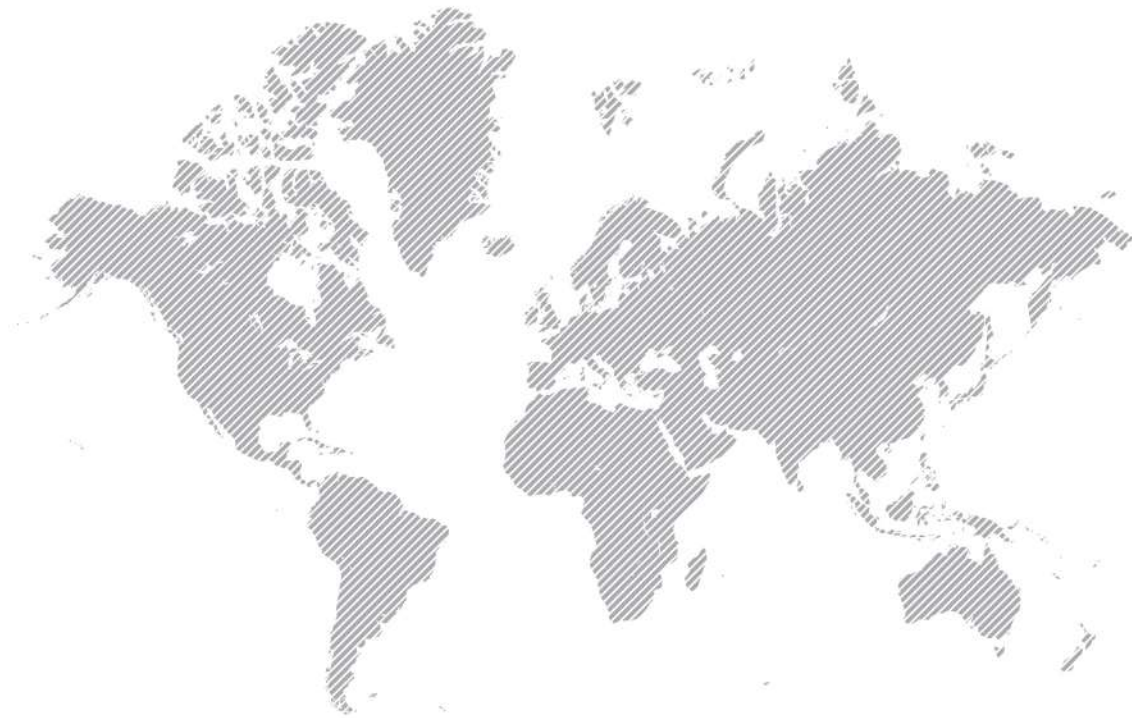

Serving Over 100 Countries Worldwide



**NAFFCO Flow Control**  
Email: [info@naffcflow.com](mailto:info@naffcflow.com)  
[www.naffcoflow.com](http://www.naffcoflow.com)

In line with NAFFCO Flow Control policy for continuous product development, NAFFCO Flow Control has the right to change specifications without prior notice.